

SAUDI TELECOM COMPANY

Reference Interconnection Offer (RIO)

Annex G

Service Schedules

Version number:	Draft 2.0
Version date:	16 th February 2006
Date of original Issue:	23 rd April 2005
Authority for issue :	GM, Regulatory Affairs
Next scheduled review date:	1 st May 2007

DOCUMENT HISTORY & VERSION CONTROL RECORD

Name of document	Service Schedules
Author	Director, Carrier Services
Authorised Officer	GM, Regulatory Affairs
Description of document	Contains the Service Schedules of the various Interconnections Services provided by STC, giving the definition, detailed description and terms of service etc.
Approved by	To be approved by CITC
Date of approval	To be approved by CITC.
Assigned review period	Annual
Date of next review	01/05/2007

Version Number	Version Date	Authorised Officer	Amendment Details
1.0	23/04/2005	GM, Regulatory Affairs	Original issue of STC Reference Interconnection Offer –Service Schedules.
Draft 2.0	16/01/2006	GM, Regulatory Affairs	<ul style="list-style-type: none"> - Clause 4.5 of Schedule 2 modified to be in line with Clause 5.4 of the Primary document. - Clause 6.3 of Schedule 8 modified to correct the wrong reference - In Schedule 4A, Clause 2 Service Definition modified for the transmission links between two OLOs. - In Schedule 2B, new Fig 1b has been added to reflect the mobile-to-mobile direct Interconnection. - In all the Schedules, the Clause title “ Billing Verification Information” changed to “ Billing Information” aligning with Annex B. - Schedule 9 for IPLC has been added. - Schedule 10 for Wholesale Internet Connectivity has been added.

LIST OF Schedules

- Schedule (1) Reserved For Future Use
- Schedule (2) Call Termination Services
 - Schedule (2A) Voice Call Termination Service To STC Geographic Number Ranges
 - Schedule (2B) Voice Call Termination Services To STC Mobile Number Ranges
 - Schedule (2C) Call Termination Service To STC Non-Geographic Number Ranges
 - Schedule (2E) Outgoing Voice Call Services To Satellite, Aeronautical And Satellite Maritime Services
- Schedule (3) Interconnect Link Services
 - Schedule (3A) Interconnect Link
- Schedule (4) Wholesale Services
 - Schedule (4A) Wholesale Transmission Link Service
 - Schedule (4B) Wholesale Outgoing International Voice Call Conveyance
 - Schedule (4C) Wholesale Incoming International Voice Call Conveyance
- Schedule (5) Collocation And Infrastructure Sharing
 - Schedule (5A) Interconnection Equipment Collocation Services
 - Schedule (5B) Infrastructure Sharing - Towers
- Schedule (6) Calls To Directory Enquiries
- Schedule (7) Calls To Emergency Services
- Schedule (8) Short Messaging Services (SMS)
- Schedule (9) Wholesale International Private Leased Circuit Service
- Schedule (10) Wholesale Internet Connectivity

SAUDI TELECOM COMPANY

Reference Interconnection Offer (RIO)

Annex G, Schedule 1

RESERVED FOR FUTURE USE

Schedule (1) Reserved For Future Use

SAUDI TELECOM COMPANY

Reference Interconnection Offer (RIO)

Annex G, Schedule 2

CALL TERMINATION SERVICES

Schedule (2) Call Termination Services

1. General

- 1.1 STC will supply Call Termination in accordance with Clause 3 (Network Interconnection) of the Primary Document in respect of the Call Types for which the processes in the relevant service provisioning clauses have been followed.
- 1.2 For the avoidance of doubt, the processes in the relevant service provisioning clauses must be initiated by the Other Licensed Operator if it wishes to acquire the Call Termination Service in respect of Calls from the Other Licensed Operator's network not previously covered by a request under the relevant service provisioning clauses.
- 1.3 STC will only be required to provide the Voice Call Termination Service to the Other Licensed Operator to the extent that the Other Licensed Operator has complied with Annex H (*Operations and Maintenance Manual*).

2. Number Range Activation

- 2.1 The Other Licensed Operator shall provide STC with at least twenty (20) Business Days notice prior to any request to open Number Range(s). The Other Licensed Operator should advise STC of details of the number range(s) to be activated, the date activation is required and provide an associated routing plan.
- 2.2 If STC can activate the number range(s) on the required date then that request will be put into effect by the due date. However where this is not possible, STC will advise within five (5) Business Days that the activation cannot be performed by the required date and will advise an alternative date by which the request can be met.

3. **Forecasts**

3.1 This Clause applies to the Forecasts to be provided by the Other Licensed Operator to STC in relation to Network Capacity required for Voice Call Termination Services.

3.2 The Other Licensed Operator shall provide STC Forecasts for Network Capacity required for the provision of the Voice Call Termination Services every six (6) months on 1 December and 1 June of each year.

3.3 Forecasts will be provided in accordance with and in the format shown in Annex E (*Forecasting*).

4. **Charging**

4.1 Unless otherwise specifically stated in the individual Service Description, charging for Voice Call Termination Services will be in accordance with this Clause.

4.2 STC will, for those Terminating Interconnected Calls for which it is providing a Voice Call Termination Service, collect a Call Data Record (CDR) for each individual Terminating Interconnected Call on a call-by-call basis and process such records in accordance with this Clause 4.

4.3 The CDRs collected by STC in accordance with this Clause shall be the source of the data used by STC for Bill Verification as per this Clause 5 and to invoice for the Voice Call Termination Service provided under this Schedule.

4.4 The calculation of Charges for the Voice Call Termination Services will be based on the number of Calls and their durations recorded on the basis of the number of applicable Billing Units, and in accordance with the applicable rates set out in Annex F (*Price List*).

4.5 Calls may be charged for the duration of use of the circuit for the Call. Charges shall not be payable under this RIO by either Licensed Operator to the

other for unsuccessful calls. Successful calls shall be defined as those calls that have passed across a POI and received an answer signal returned by the other party's network.

- 4.6 If a Call's duration extends over two (2) or more Charge Rate Periods, the Call shall be recorded as a single Call in the Charge Rate Period which applies at the commencement of the Call.
- 4.7 Calls that cross over into the next Billing Period shall be billed in the Billing Period in which those Calls end.

5. **Billing Information**

- 5.1 STC shall use its reasonable endeavours to provide the Interconnect Usage Report for the Voice Call Termination Service in accordance with the format set out in Annex B (*Billing Processes and Procedures*) within thirty (30) Business Days from the end of each Billing Period together with the invoice for the Voice Call Termination Services in accordance with Annex B (*Billing Processes and Procedures*).
- 5.2 In addition to the obligation in Clause 5.1, when there is a dispute, as defined in Annex B (*Billing Processes and Procedures*), in relation to invoices issued for the Voice Call Termination Services, then the Dispute Resolution procedures laid out in Clause 4 of Annex B (*Billing Processes and Procedures*) and Clause 19 of the Primary Document will be followed.
- 5.3 In the event that STC cannot record Billing Information for the Voice Call Termination Services due to a system error or other faults the Other Licensed Operator will be requested to provide the appropriate Billing Information to STC in accordance with the procedure set out in Annex B (*Billing Processes and Procedures*).
- 5.4 Where the Billing Information collected by the Other Licensed Operator is not available under Clause 5.3 and the procedure set out in Annex B (*Billing Processes and Procedures*), the Parties shall negotiate in good faith such

alternative Billing arrangements, such as an estimation based on the previous three (3) Billing Periods' Billing Information in accordance with the procedure set out in the procedure set out in Annex B (*Billing Processes and Procedures*) and as appropriate in the circumstances.

SAUDI TELECOM COMPANY

Reference Interconnection Offer (RIO)

Annex G, Schedule 2A

**VOICE CALL TERMINATION SERVICES
TO STC GEOGRAPHIC NUMBER RANGES**

Schedule (2A) Voice Call Termination Service To STC Geographic Number Ranges

1. General

- 1.1 STC will supply Call Termination Service to geographic number ranges in accordance with Clause 3 of the Primary Document in respect of the Call Types for which the process in Clause 4 of this Schedule (2A) has been followed.
- 1.2 For the avoidance of doubt, the process in Clause 4 of this Schedule (2A) must be initiated by the Other Licensed Operator if it wishes to acquire the Voice Call Termination Service to STC's geographic number ranges in respect of calls from the Other Licensed Operator network not previously covered by a request made under that Clause.
- 1.3 Notwithstanding the interconnection of the STC Network and the Other Licensed Operator's network, under this Schedule (2A) STC shall have no obligation to provide the Call Termination Service in respect of Calls of any type other than Voice Terminating Interconnected Calls to STC's geographic number ranges.
- 1.4 STC will only be required to provide the Voice Call Termination Service to geographic number ranges to the Other Licensed Operator to the extent that the Other Licensed Operator has complied with Annex H (*Operations and Maintenance Manual*) and this Schedule (2A).

2. Service Definition

<i>Interconnection Service</i>	<i>Definition</i>
Voice Call Termination Service to STC Geographic Number Ranges:	A Call handed over from the Other Licensed Operator Network to the STC Network, initially switched by STC's Exchanges, and passed to an STC Local Exchange (LE) for delivery to an STC Network Termination Point within that LE or parented Remote Unite (RU).

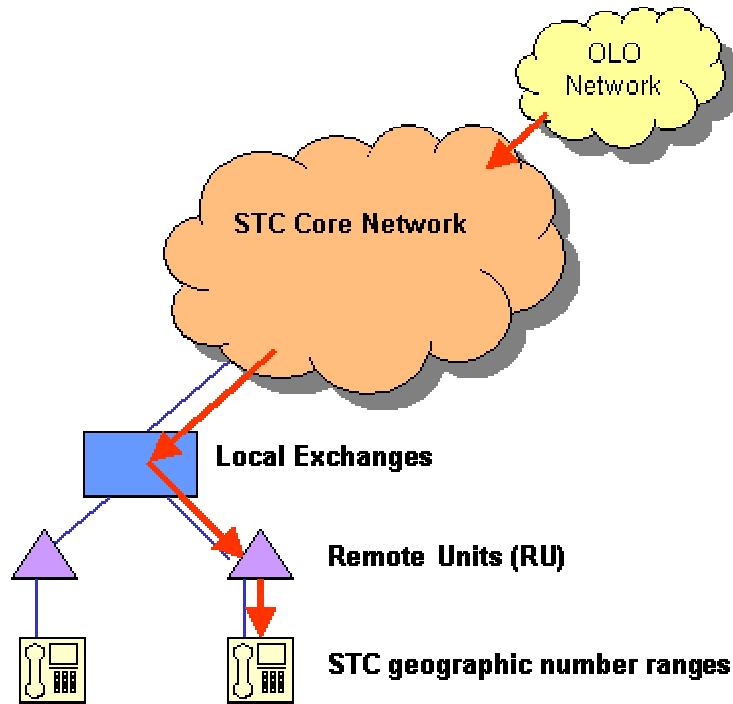

Figure 1: Voice Call Termination to STC Geographic Number Ranges

3. Description of Service

3.1 Subject to the provisions of this Schedule, STC will convey Voice Calls handed over from the Other Licensed Operator network at an STC designated Interconnection Service Node to the appropriate STC Network Termination Point for geographic number ranges.

- 3.2 The STC Voice Call Termination Service to geographic number ranges shall be limited to voice calls to geographic number ranges allocated to STC by the CITC as per the national numbering plan.
- 3.3 STC shall convey Voice Call Termination Services to STC's geographic number ranges for the Other Licensed Operator for the contracted period at the same standard and quality of service as STC conveys similar calls originated on the STC network.
- 3.4 The Interconnect Agreement Parties shall agree in advance all necessary technical requirements, including call set-up and clear down sequences, for the conveyance of calls pursuant to this Schedule.
- 3.5 Each Party shall locate and correct faults that occur in its Network which affect the conveyance of Voice Call Termination traffic in accordance with such Party's normal engineering practices. For the avoidance of doubt, neither Party warrants that its Network is, or will be, free from faults.
- 3.6 In the event that a fault in the Other Licensed Operator's network becomes service affecting in the STC network, then STC reserves the right to suspend services to the Other Licensed Operator network until such time as the cause of the fault is rectified.
- 3.7 The conveyance of Voice Call Termination Service to geographic number ranges shall be routed in accordance with the routing principles specified in Annex C (*Technical Information*). All Calls covered by this Service Schedule will be carried on installed STC Interconnect Links.
- 3.8 For the conveyance of Voice Call Termination Services to geographic number ranges by STC, the Other Licensed Operator shall pay STC a charge calculated in accordance with the rate for such a Call specified from time to time in Annex F (*Price List*).

4. **Service Provisioning – Initial Procedure**

- 4.1 This Clause 4 applies where the Other Licensed Operator wishes to use the Voice Call Termination Services to geographic number ranges provided by STC pursuant to this Schedule (2A) and in respect of which the process in this Clause 4 has not already been undertaken.
- 4.2 The Other Licensed Operator shall notify STC of its request to use Voice Call Termination Service to geographic number ranges provided by STC by means of the request form set out in Annex H (*Operations and Maintenance Manual*).
- 4.3 STC shall acknowledge, in writing to the Other Licensed Operator's nominated representative, receipt of the Other Licensed Operator's request within five (5) Business Days of its receipt.
- 4.4 Following receipt of a request for service, STC shall assess that request and notify the Other Licensed Operator within ten (10) Business Days of acknowledgement that either:
- a) The implementation of the request, in respect of the requested Voice Call Termination Services to geographic number ranges provided by STC, involves only network conditioning in STC's Network, in which case the negotiation period to agree technical interconnection arrangement prior to installation shall be thirty (30) Business Days; or
 - b) The implementation of the request in respect of the requested Voice Call Termination Service to geographic number ranges provided by STC involves work in addition to or as alternative to network conditioning in STC's Network, in which case the negotiation period to agree technical interconnection arrangement prior to installation shall be sixty (60) Business Days.
- 4.5 The Parties shall forthwith negotiate in good faith the technical requirements and timetable for the use of the Voice Call Termination Service to geographic number ranges provided by STC in accordance with the Other Licensed

Operator's request for the negotiation period specified in Clause 4.4. In the event that agreement is not reached either Party may commence the Dispute Resolution Procedure in accordance with Clause 19 of the Primary Document.

- 4.6 Where the Parties have reached an agreement, in accordance with Clause 4.5 above, STC will commence implementation in accordance with the agreed timetable as per Clause 4.5.
- 4.7 Nothing in this Clause 4 requires STC to perform any changes in its Network or to commence the supply of Voice Call Termination Service to geographic number ranges provided by STC until the Parties have completed all necessary Data Amendments required for that Voice Call Termination Service to geographic number ranges provided by STC and all network conditioning Charges in line with Annex G Schedule (3A), Interconnect Links, and the associated Prices have been agreed to by the Other Licensed Operator.
- 4.8 The Other Licensed Operator may, at any time, request STC to cease supplying the Call Termination Service to geographic number ranges provided by STC and STC shall cease supplying the Call Termination Service as soon as practicable or at such later time as specified by the Other Licensed Operator in accordance with the terms and conditions specified in Clause 20, (Breach, Suspension and Termination), of the Primary Document.

5. **Number Range Activation**

- 5.1 Notice and response times for number range activation shall be in accordance with Schedule (2) Clause 2 of this Annex G.

6. **Forecasts**

- 6.1 Forecasts shall be supplied to STC by the Other Licensed Operator in accordance with Schedule (2) Clause 3 of this Annex G.

7. **Charging**

7.1 Charging shall be in accordance with Schedule (2) Clause 4 of this Annex G.

8. **Billing Information**

8.1 Billing Verification shall be in accordance with Schedule (2) Clause 5 of this Annex G.

9. **Routing**

9.1 The conveyance of Voice Termination Calls to geographic number ranges shall be in accordance with the routing principles specified in Annex C (*Technical Information*).

SAUDI TELECOM COMPANY

Reference Interconnection Offer (RIO)

Annex G, Schedule 2B

**VOICE CALL TERMINATION SERVICES
TO STC MOBILE NUMBER RANGES**

Schedule (2B) Voice Call Termination Services To STC Mobile Number Ranges

1. General

- 1.1 STC will supply Voice Call Termination Service to STC's mobile number ranges in accordance with Clause 3 of the Primary Document in respect of the Call Types for which the process in Clause 4 of this Schedule (2B) has been followed.
- 1.2 For the avoidance of doubt, the process in Clause 4 of this Schedule (2B) must be initiated by the Other Licensed Operator if it wishes to acquire the Voice Call Termination Service to STC's mobile number ranges in respect of calls from the Other Licensed Operator network not previously covered by a request made under that Clause.
- 1.3 Notwithstanding the Interconnection of the STC Network and the Other Licensed Operator network, under this Schedule (2B) STC shall have no obligation to provide the Voice Call Termination Service in respect of calls of any type other than Voice Terminating Interconnected Calls to STC's mobile number ranges.
- 1.4 STC will only be required to provide the Voice Call Termination Service to STC's mobile number ranges to the Other Licensed Operator to the extent that the Other Licensed Operator has complied with Annex H (*Operations and Maintenance Manual*) and this Schedule (2B).

2. Service Definition

Interconnection Service	Definition
Voice Call Termination Service to STC's Mobile Number Ranges	A Voice Call handed over from the Other Licensed Operator Network to the STC Network, initially switched by STC's SN Exchanges, and passed for delivery to the STC Networks Mobile Switches for delivery to an STC Mobile network termination point.

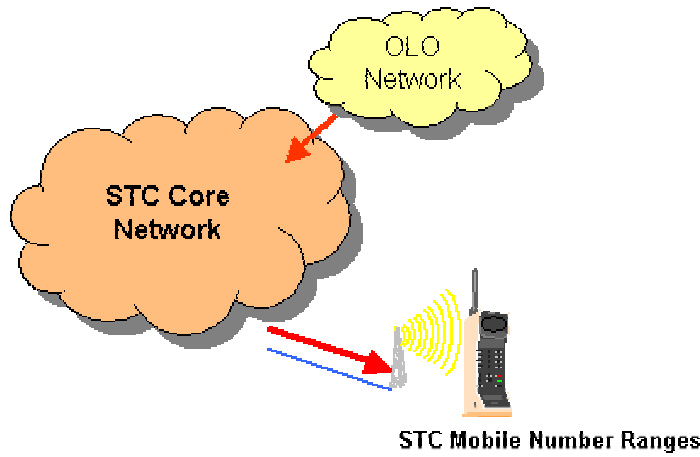

Figure 1a.: Voice Call Termination to STC Mobile Number Ranges Via Fixed Network

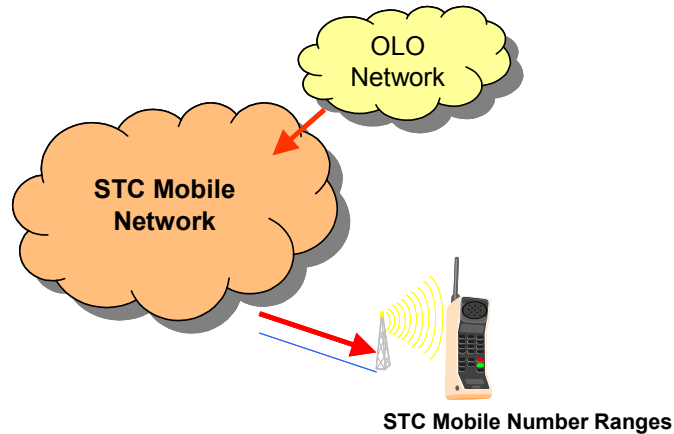

Figure 1b: Voice Call Termination to STC Mobile Number Ranges with direct Interconnection to STC Mobile Network

3. **Description of Service**

- 3.1 Subject to the provisions of this Schedule, STC shall convey Voice Calls handed over from the Other Licensed Operator network at an STC designated Interconnection Service Node to the appropriate STC Network Termination Point for STC's mobile number ranges.
- 3.2 The Voice Call Termination Service to STC's mobile number ranges shall be limited to calls to mobile number ranges allocated to STC by the CITC as per the national numbering plan.
- 3.3 STC shall convey Voice Call Termination Services to STC's mobile number ranges for the Other Licensed Operator for the contracted period at the same standard and quality of service as STC conveys similar calls originated on the STC network.
- 3.4 The Parties shall agree in advance all necessary technical requirements, including Call set-up and clear down sequences, for the conveyance of Calls pursuant to this Schedule.
- 3.5 Each Party shall locate and correct faults that occur in its Network which affect the conveyance of Call Termination traffic in accordance with such Party's normal engineering practices. For the avoidance of doubt, neither Party warrants that its Network is, or will be, free from faults.
- 3.6 In the event that a fault in the Other Licensed Operator's network becomes service affecting in the STC network, then STC reserves the right to suspend services to the Other Licensed Operator network until such time as the cause of the fault is rectified.
- 3.7 The conveyance of Voice Call Termination Service to STC's mobile number ranges shall be routed in accordance with the routing principles specified in Annex C (*Technical Information*). All Calls covered by this Service Schedule will be carried on installed STC Interconnect Links.

3.8 For the conveyance of each Voice Call Termination Services to STC's mobile number ranges by STC, the Other Licensed Operator shall pay STC a charge calculated in accordance with the rate for such a Call specified from time to time in Annex F (*Price List*).

4. **Service Provisioning – Initial Procedure**

4.1 This Clause 4 applies where the Other Licensed Operator wishes to use the Voice Call Termination Services to STC's mobile number ranges pursuant to this Schedule (2B) and in respect of which the process in this Clause 4 has not already been undertaken.

4.2 The Other Licensed Operator shall notify STC of its request for the use of Voice Call Termination Service to STC's mobile number ranges by means of the request form set out in Annex H (*Operations and Maintenance Manual*).

4.3 STC shall acknowledge, in writing, receipt of the Other Licensed Operator's request under Clause 4.2 within five (5) Business Days of its receipt.

4.4 Following receipt of a request under Clause 4.2, STC shall assess that request and notify the Other Licensed Operator within ten (10) Business Days of acknowledgement that either:

- a) The implementation of the request, in respect of the requested Voice Call Termination Services to STC's mobile number ranges, involves only network conditioning in STC's Network, in which case the negotiation period to agree technical interconnection arrangement prior to installation shall be thirty (30) Business Days; or
- b) The implementation of the request in respect of the requested Voice Call Termination Service to STC's mobile number ranges involves work in addition to or as alternative to network conditioning in STC's Network, in which case the negotiation period to agree technical interconnection arrangement prior to installation shall be sixty (60) Business Days.

- 4.5 The Parties shall forthwith negotiate in good faith the technical requirements and timetable for the use of the Voice Call Termination Service to STC's mobile number ranges in accordance with the Other Licensed Operator's request under Clause 4.2 for the negotiation period specified in Clause 4.4. In the event that agreement is not reached either Party may commence the Dispute Resolution Procedure in accordance with Clause 19 of the Primary Document.
- 4.6 Where the Parties have reached an agreement, in accordance with 4.4 above, STC will commence implementation in accordance with the agreed timetable as per Clause 4.5.
- 4.7 Nothing in this Clause 4 requires STC to perform any changes in its Network or to commence the supply of Voice Call Termination Service to STC's mobile number ranges until the Parties have completed all necessary Data Amendments required for that Call Termination Service to mobile number ranges and all network conditioning Charges in line with Schedule (3A), Interconnect Links and associated Price List have been agreed to by the Other Licensed Operator.
- 4.8 The Other Licensed Operator may, at any time, request STC to cease supplying the Voice Call Termination Service to STC's mobile number ranges and STC shall cease supplying the Voice Call Termination Services to STC's mobile number ranges as soon as practicable or at such later time as specified by the Other Licensed Operator in accordance with the terms and conditions specified in Clause 20 (Breach, Suspension and Termination), of the Primary Document.

5. **Number Range Activation**

- 5.1 Notice and response times for number range activation shall be in accordance with Schedule 2 Clause 2.

6. **Forecasts**

- 6.1 Forecasts shall be supplied to STC by the Other Licensed Operator in accordance with Schedule 2 Clause 3.

7. **Charging**

7.1 Charging shall be in accordance with Schedule 2 Clause 4 of this Annex G.

8. **Billing Information**

8.1 Billing Verification shall be in accordance with Schedule 2 Clause 5 of this Annex G.

9. **Routing**

9.1 The conveyance of Termination of Voice Calls to STC's mobile number ranges shall be in accordance with the routing principles specified in Annex C (*Technical Information*).

SAUDI TELECOM COMPANY

Reference Interconnection Offer (RIO)

Annex G, Schedule 2C

**VOICE CALL TERMINATION SERVICES
TO STC NON-GEOGRAPHIC NUMBER RANGES**

Schedule (2C) Call Termination Service To STC Non-Geographic Number Ranges

1. General

- 1.1 STC shall supply a Call Termination Service to non-geographic numbers to which the user of the non-geographic number wishes to receive calls from the Other Licensed Operator. This Call Termination Service will be provided in accordance with Clause 3 of the Primary Document in respect of the Call Types for which the process in Clause 4 of this Schedule (2C) has been followed.
- 1.2 For the avoidance of doubt, the process in Clause 4 of this Schedule (2C) must be initiated by the Other Licensed Operator if it wishes to acquire the Voice Call Termination Service in respect of calls from the Other Licensed Operator network not previously covered by a request made under that Clause.
- 1.3 Notwithstanding the Interconnection of the STC Network and the Other Licensed Operator network, under this Schedule (2C), STC shall have no obligation to provide the Call Termination Service in respect of Calls of any type other than Voice Band Terminating Interconnected Calls to STC's non-geographic number ranges.
- 1.4 STC shall only be required to provide the Voice Call Termination Service to non-geographic number ranges to the Other Licensed Operator to the extent that the Other Licensed Operator has complied with Annex H (*Operations and Maintenance Manual*) and this Schedule (2C).

2. Service definition

<i>Interconnection Service</i>	<i>Definition</i>
Call Termination Service to STC Non Geographic Number Ranges	A Call, handed over from the Other Licensed Operator Network to the STC Network, using a look-up in a number database and appropriately routed to an STC LE for delivery to a STC Network Termination Point within that LE or parented RU or network call centre.

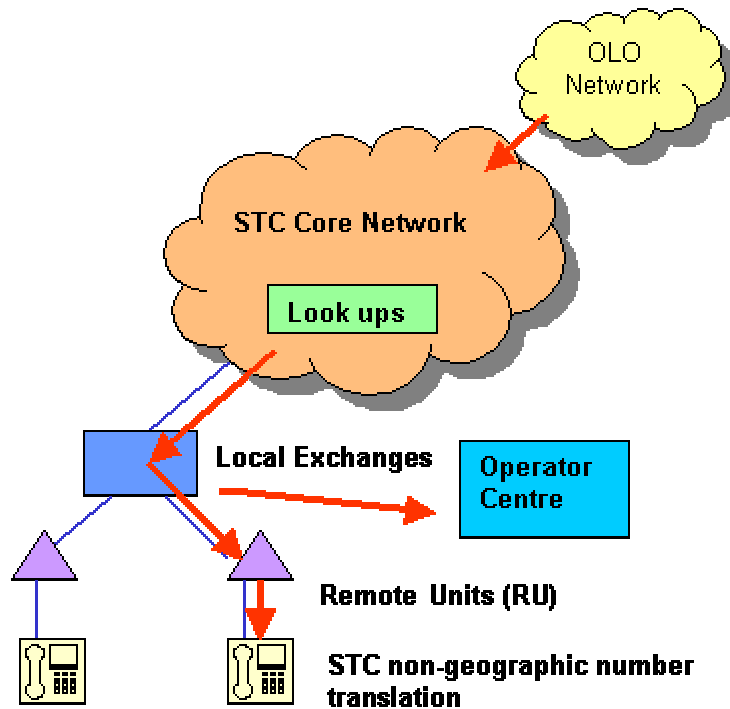

Figure 1: Call Termination to STC Non Geographic Number Ranges

3. Description of Service

3.1 Subject to the provisions of this Schedule, STC shall convey Voice Calls handed over from the Other Licensed Operator network at an STC designated Interconnection Service Node to the appropriate STC Network Termination Point for non-geographic number ranges.

- 3.2 The STC Voice Call Termination Service to non-geographic number ranges shall be limited to voice calls to non-geographic number ranges allocated to STC by the CITC as per the national numbering plan.
- 3.3 STC shall convey Voice Call Termination Services to STC's non-geographic number ranges for the Other Licensed Operator for the contracted period at the same standard and quality of service as STC conveys similar calls originating on the STC network.
- 3.4 The Parties shall agree in advance all necessary technical requirements, including call set-up and clear down sequences, for the conveyance of calls pursuant to this Schedule.
- 3.5 Each Party shall locate and correct faults that occur in its Network which affect the conveyance of Voice Call Termination traffic in accordance with such Party's normal engineering practices. For the avoidance of doubt, neither Party warrants that its Network is, or will be, free from faults.
- 3.6 In the event that a fault in the Other Licensed Operator's network becomes service affecting in the STC network, then STC reserves the right to suspend services to the Other Licensed Operator network until such time as the cause of the fault is rectified.
- 3.7 The conveyance of Voice Band Call Termination Service to non-geographic number ranges shall be routed in accordance with the routing principles specified in Annex C (*Technical Information*). All Calls covered by this Service Schedule will be carried on installed STC Interconnect Links.
- 3.8 For the conveyance of Voice Band Call Termination Services to non-geographic number ranges by STC, the Other Licensed Operator shall pay STC and STC shall pay the Other Licensed Operator the charges calculated in accordance with the rates for such a Call specified from time to time in Annex F (*Price List*).

4. **Service Provisioning – Initial Procedure**

- 4.1 This Clause 4 applies where the Other Licensed Operator wishes to use the Voice Call Termination Services to non-geographic number ranges provided by STC pursuant to this Schedule (3A) and in respect of which the process in this Clause 4 has not already been undertaken.
- 4.2 The Other Licensed Operator shall notify STC of its request for the use of Voice Call Termination Service to non-geographic number ranges by means of the request form set out in Annex H (*Operations and Maintenance Manual*).
- 4.3 STC shall acknowledge, in writing to the Other Licensed Operator's nominated representative, receipt of the Other Licensed Operator's request under Clause 4.2 within five (5) Business Days of its receipt.
- 4.4 Following receipt of a request under Clause 4.2, STC shall assess that request and notify the Other Licensed Operator within ten (10) Business Days of acknowledgement that either:
- a) The implementation of the request, in respect of the requested Voice Call Termination Services to non geographic number ranges, involves only network conditioning in STC's Network, in which case the negotiation period to agree technical interconnection arrangement prior to installation shall be thirty (30) Business Days; or
 - b) The implementation of the request in respect of the requested Voice Call Termination Service to non geographic number ranges involves work in addition to or as alternative to network conditioning in STC's Network, in which case the negotiation period to agree technical interconnection arrangement prior to installation shall be sixty (60) Business Days.
- 4.5 The Parties shall forthwith negotiate in good faith the technical requirements and timetable for the use of the Call Termination Service to non geographic number ranges provided by STC in accordance with the Other Licensed Operator's request under Clause 4.2 for the negotiation period specified in

Clause 4.4. In the event that agreement is not reached either Party may commence the Dispute Resolution Procedure in accordance with Clause 19 of the Primary Document.

4.6 Where the Parties have reached an agreement, in accordance with 4.4 above, STC will commence implementation in accordance with the agreed timetable as per Clause 4.5.

4.7 Nothing in this Clause 4 requires STC to perform any changes in its Network or to commence the supply of Voice Call Termination Service to non geographic number ranges until the Parties have completed all necessary Data Amendments required for that Voice Call Termination Service to non geographic number ranges and all network conditioning Charges in line with Schedule (3A), Interconnect Links, and associated Price list have been agreed to by the Other Licensed Operator.

4.8 The Other Licensed Operator may, at any time, request STC to cease supplying the Call Termination Service to non geographic number ranges and STC shall cease supplying the Call Termination Service as soon as practicable or at such later time as specified by the Other Licensed Operator in accordance with the terms and conditions specified in Clause 20 (Breach, Suspension and Termination), of the Primary Document.

5. **Number Range Activation**

5.1 Notice and response times for number range activation shall be in accordance with Schedule 2 Clause 2.

6. **Forecasts**

6.1 Forecasts shall be supplied to STC by the Other Licensed Operator in accordance with Schedule 2 Clause 3.

7. **Charging**

7.1 Charging shall be in accordance with Schedule 2 Clause 4.

8. **Billing Information**

8.1 Billing Verification shall be in accordance with Schedule 2 Clause 5.

9. **Routing**

9.1 The conveyance of Voice Band Termination Calls to non-geographic number ranges shall be in accordance with the routing principles specified in Annex C (*Technical Information*).

SAUDI TELECOM COMPANY

Reference Interconnection Offer (RIO)

Annex G, Schedule 2E

**OUTGOING VOICE CALL SERVICES
TO SATELLITE, AERONAUTICAL AND
SATELLITE MARITIME SERVICES**

Schedule (2E) Outgoing Voice Call Services To Satellite, Aeronautical And Satellite Maritime Services

1. General

- 1.1 STC shall supply the Outgoing Voice Call Services to Satellite and Satellite Maritime Services from the Other Licensed Operator's Network through STC's Network in accordance with Clause 3 of the Primary Document in respect of the Outgoing Voice Call Services to Satellite and Satellite Maritime Services for which the process in Clause 4 of this Schedule (2E) has been followed; and a network specific charge exists in Annex F (*Price List*).
- 1.2 STC shall only provide Outgoing Voice Call Services to Satellite and Satellite Maritime Services under this Schedule (2E) to the Other Licensed Operator in respect to third party networks which are connected to the STC Network directly or indirectly.
- 1.3 For the avoidance of doubt, the process in Clause 4 of this Schedule (2E) must be initiated by the Other Licensed Operator if it wishes to acquire the Outgoing Voice Call Service to Satellite and Satellite Maritime Services in respect of calls from the Other Licensed Operator network not previously covered by a request made under that Clause.
- 1.4 STC shall only be required to provide the Outgoing Voice Call Service to Satellite and Satellite Maritime Services number ranges to the Other Licensed Operator to the extent that the Other Licensed Operator has complied with Annex H (*Operations and Maintenance Manual*) and this Schedule (2E).

2. Service Definition

<i>Interconnection Service</i>	<i>Definition</i>
Voice Call Termination Service to Satellite, Aeronautical and Maritime Services Number Ranges	A Voice Call handed over from the Other Licensed Operator Network to the STC Network, initially switched by STC's Exchanges, and passed for delivery to the owner of the respective Satellite, Aeronautical and Maritime Services network.

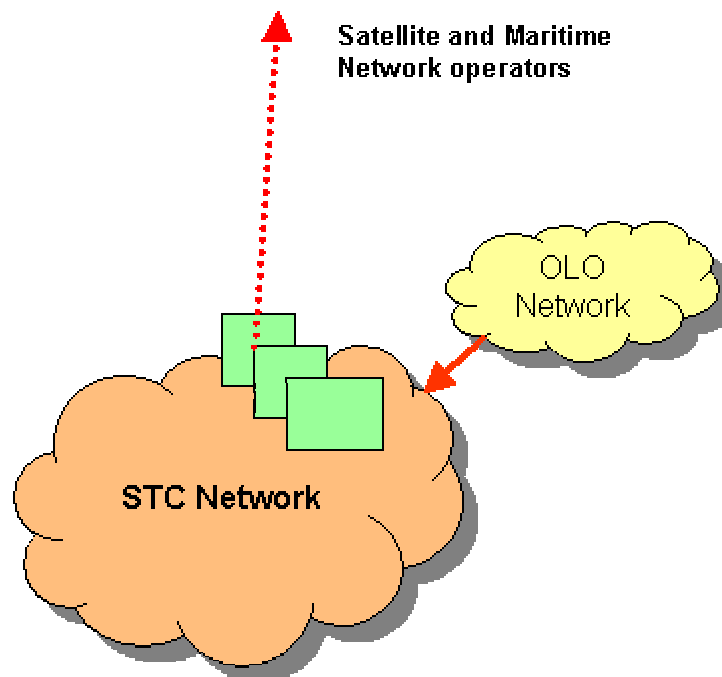

Figure 1: Voice Call Termination Service to Satellite, Aeronautical and Maritime Services

3. Description of Service

3.1 Subject to the provisions of this Schedule (2E), STC shall only convey Outgoing Voice Calls to Satellite and Satellite Maritime Services which are handed over from the Other Licensed Operator Network to a Third Party Network Operator's Network, if a rate for such a Call is specified in Annex F (*Price List*).

- 3.2 STC and the Other Licensed Operator shall agree in advance all necessary technical requirements, including call set-up and clear down sequences, for the conveyance of calls pursuant to this Schedule.
- 3.3 STC shall not be obliged under this Schedule to make its Network suitable for the conveyance of ISDN Outgoing Calls or to provide equipment to its Customers enabling ISDN International Outgoing Calls.
- 3.4 STC shall convey Outgoing Voice Calls to Satellite, Aeronautical and Satellite Maritime Services for the contract period and at the same standard and quality of service as it conveys similar Calls originating in the STC network.
- 3.5 STC will only convey outgoing voice calls to Satellite, Aeronautical and Satellite Maritime Services to those operators listed as only being available through the STC Operator after appropriate technical operational and commercial arrangements, including billing have been successfully negotiated and implemented between the parties.
- 3.6 Each Party shall locate and correct faults that occur in its Network which affect the conveyance of Outgoing Voice Calls to Satellite, Aeronautical and Satellite Maritime Services in accordance with such Party's normal engineering practices. For the avoidance of doubt, neither Party warrants that its Network is, or will be, free from faults.
- 3.7 In the event that a fault in the Other Licensed Operator's network becomes service affecting in the STC network, then STC reserves the right to suspend services to the Other Licensed Operator network until such time as the cause of the fault is rectified.

4. **Service Provisioning – Initial Procedure**

- 4.1 This Clause 4 applies where the Other Licensed Operator wishes to use the Outgoing Voice Call Services to Satellite, Aeronautical and Satellite Maritime Services provided by STC pursuant to this Schedule (2E) and in respect of which the process in this Clause 4 has not already been undertaken.

- 4.2 The Other Licensed Operator shall notify STC by means of a request form as set out in Annex H (*Operations and Maintenance Manual*).
- a) To use a particular Outgoing Voice Call Services to Satellite and Satellite Maritime Services; or
 - b) To extend the provision of the Outgoing Voice Call Services to Satellite and Satellite Maritime Services to a particular Third Party Network.
- 4.3 STC shall acknowledge, in writing, receipt of the Other Licensed Operator's request under Clause 4.2 within five (5) Business Days.
- 4.4 Following receipt of a request under Clause 4.2, STC shall assess that request and notify the Other Licensed Operator within ten (10) Business Days of acknowledgement that either:
- a) The implementation of the request, in respect of the requested Outgoing Voice Call Services to Satellite, Aeronautical and Satellite Maritime Services, involves only network conditioning in STC's Network, in which case the negotiation period to agree technical interconnection arrangement prior to installation shall be thirty (30) Business Days; or
 - b) The implementation of the request in respect of the requested Outgoing Voice Call Services to Satellite, Aeronautical and Satellite Maritime Services involves work in addition to or as alternative to network conditioning in STC's Network, in which case negotiation period to agree the technical interconnection arrangement prior to installation shall be sixty (60) Business Days.
- 4.5 The Parties shall forthwith negotiate in good faith the requirements, implementation Charges and timetable for the use of the Outgoing Voice Call Services to Satellite, Aeronautical and Satellite Maritime Services provided by STC in accordance with the Other Licensed Operator's request under Clause 4.2 for the negotiation period notified in Clause 4.4. In the event that

agreement is not reached either Party may commence the Dispute Resolution Procedure in accordance with Clause 19 of the Primary Document.

- 4.6 Where the Parties have reached an agreement, in accordance with Clause 4.5 above, STC will commence implementation in accordance with the agreed timetable.
- 4.7 Nothing in this Clause 4 requires STC to perform any changes in its Network or to commence the supply of Outgoing Voice Call Services to Satellite, Aeronautical and Satellite Maritime Services until the Parties have completed all necessary Data Amendments required for that Outgoing Voice Call Services to Satellite and Satellite Maritime Services and all network conditioning Charges in line with Schedule (3A), Interconnect Links, and associated Price List, have been agreed to by the Other Licensed Operator.
- 4.8 The Other Licensed Operator may, at any time, request STC to cease supplying the Outgoing Voice Call Services to Satellite, Aeronautical and Satellite Maritime Services and STC shall cease supplying the Outgoing Voice Call Services to Satellite, Aeronautical and Satellite Maritime Services as soon as practicable or at such later time as specified by the Other Licensed Operator in accordance with the terms and conditions specified in Clause 20 (Breach, Suspension and Termination), of the Primary Document.

5. **Number Range Activation**

- 5.1 Notice and response times for number range activation shall be in accordance with Schedule 2 Clause 2.

6. **Forecasts**

- 6.1 Forecasts shall be supplied to STC by the Other Licensed Operator in accordance with Schedule 2 Clause 3.

7. **Charging**

- 7.1 Charging shall be in accordance with Schedule 2 Clause 4.

8. **Billing Information**

8.1 Billing Verification shall be in accordance with Schedule 2 Clause 5.

9. **Routing**

9.1 The conveyance of Outgoing Voice Calls to Satellite and Satellite Maritime Services number ranges shall be in accordance with the routing principles specified in Annex C (*Technical Information*).

SAUDI TELECOM COMPANY

Reference Interconnection Offer (RIO)

Annex G, Schedule 3

INTERCONNECT LINK SERVICES

Schedule (3) Interconnect Link Services

1. General

1.1 This Schedule sets out the terms and conditions under which STC will provide the Transmission Link Services to each Other Licensed Operator.

1.2 This Schedule is comprised of the following section:

Schedule (3A) – Interconnect Link

1.3 In this Schedule, a reference to a Clause or Annex unless stated otherwise, is to a Clause or Annex of this Schedule.

SAUDI TELECOM COMPANY

Reference Interconnection Offer (RIO)

Annex G, Schedule 3A

INTERCONNECT LINK

Schedule (3A) Interconnect Link

1. General

- 1.1 STC will supply the Interconnect Link to the Other Licensed Operator in accordance with Clause 3 of the Primary Document in respect of the Services for which the process in Clause 4 of this Schedule (3A) has been followed.
- 1.2 For the avoidance of doubt, the process in Clause 4 of this Schedule (3A) must be initiated by the Other Licensed Operator if it wishes to acquire the Interconnect Link not previously covered by a request made under that Clause.
- 1.3 Notwithstanding the Interconnection of the STC Network and the Other Licensed Operator's network, STC shall have no obligation to provide the Interconnect Link at sites not designated as Points of Interconnection (POI).
- 1.4 STC will only be required to provide the Interconnect Link to the Other Licensed Operator to the extent that the Other Licensed Operator has complied with Annex H (*Operations and Maintenance Manual*) and this Schedule (3A).

2. Service Definition

<i>Interconnection Service</i>	<i>Definition</i>
Interconnect Link	A service where STC provides fixed transmission capacity over which traffic between its network and the network of the Other Licensed Operator flows. Each end of the interconnect link is terminated on the network of a different licensee.

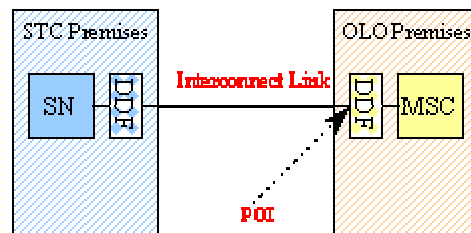

Figure 1: Interconnect Link Between STC Site and Other Licensed Operator Site

3. Description of Service

- 3.1 Subject to the provisions of this Interconnect Link Service Schedule, STC shall provide links with requested capacity between a requested STC POI and a specified point in an Other Licensed Operator site.
- 3.2 For the avoidance of doubt, the Interconnect Link is not provided for links to Third Party Networks.
- 3.3 STC shall provide the Interconnect Link for the Other Licensed Operator for the contract period and at the same standard and quality of service as STC provides for similar links in its own network.
- 3.4 The Parties shall agree in advance all necessary technical requirements, including physical circuit installation and operation, for the provision of the Interconnect Link pursuant to this Service Schedule (3A).
- 3.5 Each Party shall locate and correct faults that occur in its Network which affect the performance of the Interconnect Link in accordance with each Party's normal engineering practices. For the avoidance of doubt, neither Party warrants that its Network is, or will be, free from faults.
- 3.6 In the event that a fault in the Other Licensed Operator's network becomes service affecting in the STC network, then STC reserves the right to suspend services to the Other Licensed Operator network until such time as the cause of the fault is rectified.

- 3.7 The provision of the Interconnect Link shall be in accordance with the STC Transmission routing principles specified in Annex C (*Technical Information*).
- 3.8 The Interconnect Link will be provided using the agreed appropriate technology including both fixed and wireless systems.
- 3.9 For the provision of each Interconnect Link, the Other Licensed Operator shall pay STC in accordance with the rate for such a Link as specified from time to time in Annex F (*Price List*).

4. **Service Provisioning – Initial Procedure**

- 4.1 This Clause 4 applies where the Other Licensed Operator wishes to use the Interconnect Link provided by STC pursuant to this Schedule (3A) and in respect of which the process in this Clause 4 has not already been undertaken.
- 4.2 The Other Licensed Operator shall notify STC by means of the request form set out in Annex H (*Operations and Maintenance Manual*) if it wishes to use the Interconnect Link.
- 4.3 STC shall acknowledge, in writing, receipt of the Other Licensed Operator's request under Clause 4.2 within five (5) Business Days of its receipt.
- 4.4 Following receipt of a request under Clause 4.2, STC shall assess that request and notify the Other Licensed Operator within ten (10) Business Days that either;
- a) The implementation of the request in respect of the requested Interconnect Link involves only network conditioning in STC's Network, in which case the negotiation period shall be thirty (30) Business Days; or
 - b) The implementation of the request in respect of the requested Interconnect Link involves work in addition to or as alternative to network conditioning in STC's Network, in which case the negotiation period shall be sixty (60) Business Days.
 - c) Facilities are unavailable.

- 4.5 The Parties shall forthwith negotiate in good faith the requirements, implementation charges and timetable for the use of the Interconnect Link provided by STC in accordance with the Other Licensed Operator's request under Clause 4.2 for the negotiation period specified in Clause 4.4 (a) and (b), failing which either Party may commence the Dispute resolution Procedure in accordance with Clause 19 of the Primary Document.
- 4.6 Where the Parties have reached an agreement, in accordance with 4.4 (a) and (b) above, STC will commence implementation in accordance with the agreed timetable and in line with the delivery schedules contained in Annex I (*Quality of Service Measure*).
- 4.7 Nothing in this Clause 4 requires STC to perform any changes in its Network or to commence the supply of Interconnect Link until the Parties have completed the preparation for that Interconnect Link and all network conditioning charges have been agreed to by the Other Licensed Operator.
- 4.8 The Other Licensed Operator may, at any time, request STC to cease supplying the Interconnect Link and STC shall cease supplying the Interconnect Link as soon as practicable or at such later time as specified by the Other Licensed Operator in accordance with the terms and conditions specified in Clause 20 (Breach, Suspension and Termination) of the Primary Document.
5. **Charging**
- 5.1 For all Interconnect Links provided by STC, STC will collect the Interconnect Link charges from the Other Licensed Operator.
- 5.2 STC shall, for those links for which it is providing an Interconnect Link, collate a record for each individual link which will be used by STC to invoice for the Interconnect Link it provides under this RIO.
- 5.3 The calculation of charges for the Interconnect Link will be based on the applicable rates set out in Annex F (*Price List*).

5.4 Charging commences upon the formal completion and handover of each circuit.

6. **Billing Information**

6.1 STC shall use its reasonable endeavours to provide appropriate Billing Information for the Interconnect Link in accordance with the format set out in Annex B (*Billing Processes and Procedures*) within thirty (30) Business Days from the end of each Billing Period, together with the invoice for the Interconnect Link in accordance with Annex B (*Billing Processes and Procedures*).

6.2 In addition to the obligation in Clause 6.1, when there is a dispute in relation to invoices issued for the Interconnect Link, the parties shall exchange the appropriate Billing Information set out in Annex B (*Billing Processes and Procedures*).

6.3 In the event that STC cannot provide the appropriate Billing Information for the Interconnect Link due to a system error or other faults, upon request of STC, the Other Licensed Operator will be requested to provide appropriate Billing Information to STC in accordance with the procedure set out in Annex B (*Billing Processes and Procedures*).

6.4 Where the Billing Information collected by the Other Licensed Operator is not available under Clause 6.3 and the procedure set out in Annex B (*Billing Processes and Procedures*), the Parties shall negotiate in good faith alternative Billing arrangements as may be appropriate in the circumstances.

7. **Routing**

7.1 The provision of Interconnect Links shall be in accordance with the STC Transmission routing principles specified in Annex C (*Technical Information*).

SAUDI TELECOM COMPANY

Reference Interconnection Offer (RIO)

Annex G, Schedule 4

WHOLESALE SERVICES

Schedule (4) Wholesale Services

1. General

- 1.1 STC will supply Wholesale Services in accordance with Clause 3 of the Primary Document in respect of the Services for which the processes in the relevant service provisioning clauses have been followed.
- 1.2 For the avoidance of doubt, the process in the relevant service provisioning clauses must be initiated by the Other Licensed Operator if it wishes to acquire Wholesale Services not previously covered by a request under the relevant service provisioning clauses.
- 1.3 STC will only be required to provide the Wholesale Services to the Other Licensed Operator to the extent that the Other Licensed Operator has complied with Annex H (*Operations and Maintenance Manual*).

2. Forecasts

- 2.1 This Clause applies to the forecasts to be provided by the Other Licensed Operator to STC in relation to network capacity required for wholesale services.
- 2.2 The Other Licensed Operator shall provide STC forecasts for network capacity required for the provision of the wholesale services every six (6) months on 1 December and 1 June of each year.
- 2.3 Forecasts will be provided in accordance with and in the format shown in Annex E (*Forecasting*).

3. Charging

- 3.1 Unless otherwise specifically stated in the individual Service Description, charging for wholesale services will be in accordance with this Clause.

- 3.2 STC shall, for those calls for which it is providing a Wholesale Voice Call Conveyance Services, collect a Call Data Record (CDR) for each individual call on a call-by-call basis and process such records in accordance with this Clause 4.
- 3.3 The CDRs collected by STC in accordance with this Clause 4 shall be the source of the data used by STC for bill verification as per Clause 5 and to invoice for the Wholesale Voice Call Conveyance Service provided under this Schedule.
- 3.4 The calculation of Charges for the Wholesale Voice Call Conveyance Services will be based on the number of Calls and their durations recorded on the basis of the applicable Billing Unit, and in accordance with the applicable rates set out in Annex F (*Price List*).
- 3.5 Calls may be charged for the initiation of use and for the duration of use of the circuit for the Call. The use of a circuit shall start at the time the circuit used for the Call is seized and end at the time the circuit is released. All successful calls are chargeable. The call duration Billing Unit shall be in increments of one (1) second.
- 3.6 If a Call's duration extends over two (2) or more Charge Rate Periods, the Call shall be recorded as a single Call in the Charge Rate Period which applies at the commencement of the Call.
- 3.7 Calls that cross over into the next Billing Period shall be billed in the Billing Period in which those Calls end.

4. **Billing Information**

- 4.1 STC shall use its reasonable endeavours to provide appropriate Billing Information for Wholesale Service in accordance with the format set out in Annex B (*Billing Processes and Procedures*) within thirty (30) Business Days from the end of each Billing Period together with the invoice for the Wholesale Services in accordance with Annex B (*Billing Processes and Procedures*).

- 4.2 In addition to the obligation in Clause 5.1, when there is a dispute, as defined in Annex B (*Billing Processes and Procedures*), in relation to invoices issued for the Wholesale Services, then the reconciliation procedures laid out in Clause 4 of Annex B (*Billing Processes and Procedures*) and Clause 19 of the Primary Document will be followed.
- 4.3 In the event that STC cannot record Billing Information for the Wholesale Services due to a system error or other faults the Other Licensed Operator will be requested to provide appropriate Billing Information to STC in accordance with the procedure set out in Annex B (*Billing Processes and Procedures*).
- 4.4 Where the Billing Information collected by the Other Licensed Operator is not available under Clause 5.3, the Parties shall negotiate in good faith such alternative Billing arrangements, such as an estimation based on the previous three (3) Billing Period's Billing Information in accordance with the procedure set out in Annex B (*Billing Processes and Procedures*) and as appropriate in the circumstances.

SAUDI TELECOM COMPANY

Reference Interconnection Offer (RIO)

Annex G, Schedule 4A

**WHOLESALE TRANSMISSION LINK
SERVICES**

Schedule (4A) Wholesale Transmission Link Service

1. General

- 1.1 STC will supply the Transmission Link Service to the Other Licensed Operator in accordance with Clause 3 of the Primary Document in respect of the Services for which the process in Clause 4 of the this Schedule (4A) has been followed.
- 1.2 For the avoidance of doubt, the process in Clause 4 of this Schedule (4A) must be initiated by the Other Licensed Operator if it wishes to acquire the Transmission Link Services not previously covered by a request made under that Clause.
- 1.3 Notwithstanding the Interconnection of STC's Network and the Other Licensed Operator's network, STC shall have no obligation to provide the Transmission Link Service other than those specified for the provision of retail Leased Line Services including standard delivery lead-times where appropriate plant is available, extended lead-times where plant is not available as well as engineering and commercial principles.
- 1.4 STC will only be required to provide the Transmission Link Service to the Other Licensed Operator to the extent that the Other Licensed Operator has complied with Annex H (*Operations and Maintenance Manual*) and this Schedule (4A).

2. Service Definition

<i>Interconnection Service</i>	<i>Definition</i>
Wholesale Transmission Link Service	A service where STC provides fixed transmission capacity between 2 fixed points over its network via Transmission Node sites to an Other Licensed Operator's property/site or between the property/site of two Other Licensed Operators.

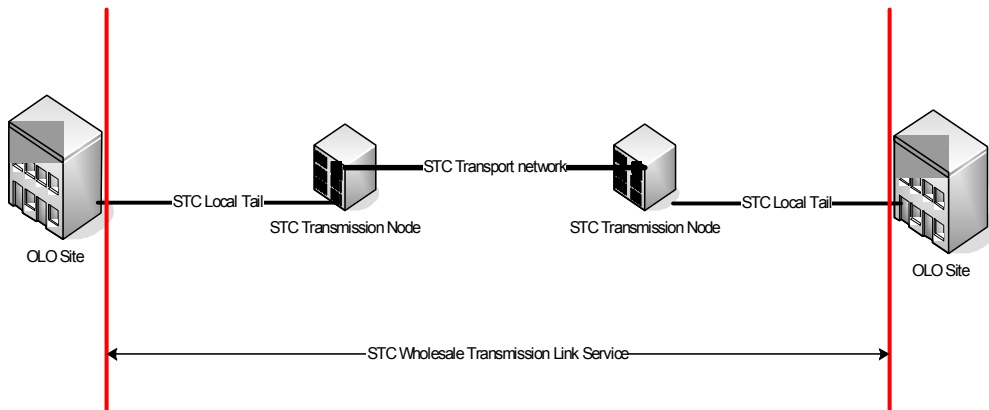

Figure 1: Wholesale Transmission Link Service from Other Licensed Operator site to Other Licensed Operator site

3. Description of Service

- 3.1 Subject to the provisions of this Schedule, STC shall provide the Wholesale Transmission Link Service between Other Licensed Operator(s) sites.
- 3.2 STC shall provide the Wholesale Transmission Link Service for the Other Licensed Operator for the contract period and at the same standard and quality of service as it provides for similar links.
- 3.3 The Parties shall agree in advance all necessary technical requirements, including physical circuit installation and operation for the provision of the Wholesale Transmission Link Service pursuant to this Schedule.

- 3.4 Each Party shall locate and correct faults that occur in its Network which affect the performance of the Wholesale Transmission Link Service in accordance with such Party's normal engineering practices. For the avoidance of doubt, neither Party warrants that its Network is, or will be, free from faults.
- 3.5 The provision of the Wholesale Transmission Link Service shall be in accordance with the STC Transmission routing principles specified in Annex C (*Technical Information*).
- 3.6 The Wholesale Transmission Link service will be provided using agreed appropriate technology including both fixed and wireless systems.
- 3.7 For the provision of each Wholesale Transmission Link Service, the Other Licensed Operator shall pay STC charges in accordance with the rate for such a Link as specified from time to time in Annex F (*Price List*).

4. **Service Provisioning – Initial Procedure**

- 4.1 This Clause 4 applies where the Other Licensed Operator wishes to use the Wholesale Transmission Link Service provided by STC in respect of which the process in this Clause 4 has not already been undertaken.
- 4.2 The Other Licensed Operator shall notify STC by means of the request form set out in Annex H (*Operations and Maintenance Manual*) if it requests the use of a Wholesale Transmission Link Service.
- 4.3 STC shall acknowledge, in writing, receipt of the Other Licensed Operator's request under Clause 4.2 within five (5) Business Days of its receipt.
- 4.4 Following receipt of a request under Clause 4.2, STC shall assess that request and notify the Other Licensed Operator within ten (10) Business Days that either:
- a) The implementation of the request in respect of the requested Transmission Link Service involves only network conditioning in STC's Network, in which case the negotiation period shall be thirty (30) Business Days; or

- b) The implementation of the request in respect of the requested Transmission Link Service involves work in addition to or as alternative to network conditioning in STC's Network, in which case the negotiation period shall be sixty (60) Business Days, or
- c) Facilities are unavailable.

- 4.5 The Parties shall forthwith negotiate in good faith the requirements, implementation charges and timetable for the use of the Transmission Link Service provided by STC in accordance with the Other Licensed Operator's request under Clause 4.2 for the negotiation period specified in Clause 4.4 (a) and (b) failing which either Party may commence the Dispute Resolution Procedure as defined in Clause 19 of the Primary Document.
- 4.6 Where the Parties have reached an agreement, in accordance with 4.4 (a) and (b) above, STC will commence implementation in accordance with the agreed timetable and in line with the delivery schedules contained in Annex I (*Quality of Service Measure*).
- 4.7 Nothing in this Clause 4 requires STC to perform any changes in its Network or to commence the supply of the Transmission Link Service until the Parties have completed the preparation for that Transmission Link Service and all network conditioning Charges have been agreed to by the Other Licensed Operator.
- 4.8 The Other Licensed Operator may, at any time, request STC to cease supplying the Transmission Link Service and STC shall cease supplying the Transmission Link Service as soon as practicable or at such later time as specified by the Other Licensed Operator in accordance with terms and conditions specified in Clause 20 (Breach, Suspension and Termination) of the Primary Document.

5. **Charging**

- 5.1 For all Wholesale Transmission Link Services provided by STC, STC will collect the Wholesale Transmission Link Service charges from the Other Licensed Operator.
- 5.2 STC shall, for those Links for which it is providing a Wholesale Transmission Link Service, collate a record for each individual Link which shall be used by STC to invoice for the Wholesale Transmission Link Service it provides under this RIO.
- 5.3 The calculation of Charges for the Wholesale Transmission Link Service will be based on the applicable rates set out in Annex F (*Price List*).
- 5.4 Charging commences upon the formal completion and handover of each circuit.
- 5.5 When the Wholesale Transmission Link Service is provided to an Other Licensed Operator in order to link it to the network of a third party Other Licensed Operator, the Other Licensed Operator which first requests STC for the provision of such a Wholesale Transmission Link Service will be responsible for the payment of all connection and rental charges to STC.

6. **Billing Information**

- 6.1 STC shall use its reasonable endeavours to provide appropriate Billing Information for the Wholesale Transmission Link Service in accordance with the format set out in Annex B (*Billing Processes and Procedures*) within thirty (30) Business Days from the end of each Billing Period together with the invoice for the Wholesale Transmission Link Service in accordance with Annex B (*Billing Processes and Procedures*).

- 6.2 In addition to the obligation in Clause 6.1, when there is a dispute in relation to invoices issued for the Wholesale Transmission Link Service, the parties shall exchange the appropriate Billing Information.
- 6.3 In the event that STC cannot provide Billing Information for the Wholesale Transmission Link Service due to a system error or other faults, the Other Licensed Operator will be requested to provide appropriate Billing Information to STC in accordance with the procedure set out in Annex B (*Billing Processes and Procedures*).
- 6.4 Where the Billing Information collected by the Other Licensed Operator is not available under Clause 6.3, the Parties shall negotiate in good faith alternative Billing arrangements.
7. **Routing**
- 7.1 The provision of Transmission Links shall be in accordance with the STC Transmission routing principles specified in Annex C (*Technical Information*).

SAUDI TELECOM COMPANY

Reference Interconnection Offer (RIO)

Annex G, Schedule 4B

**WHOLESALE OUTGOING INTERNATIONAL
VOICE CALL CONVEYANCE**

Schedule (4B) Wholesale Outgoing International Voice Call Conveyance

1. General

1.1 STC shall supply the Wholesale Outgoing International Voice Call Conveyance Services from the Other Licensed Operator's Network through STC's Network in accordance with Clause 3 of the Primary Document in respect of the Wholesale Outgoing International Voice Call Conveyance Services for which the process in Clause 4 of this Schedule (4B) has been followed; and a country specific charge exists in Annex F (*Price List*).

1.2 STC shall only provide Wholesale Outgoing International Voice Call Conveyance Services under this Schedule to the Other Licensed Operator in respect to Third Party Networks which are connected to the STC Network directly or indirectly.

2. Service Definitions

<i>Interconnection Service</i>	<i>Definition</i>
Wholesale Outgoing International Voice Call Conveyance	An Outgoing International Voice Call, handed over from the Other Licensed Operator Network to the STC Network, switched by STC's Exchanges for delivery to an STC International Gateway (IGW) Exchange. The STC IGW then provides connectivity for termination of the voice call abroad. Additional International termination charges may apply.

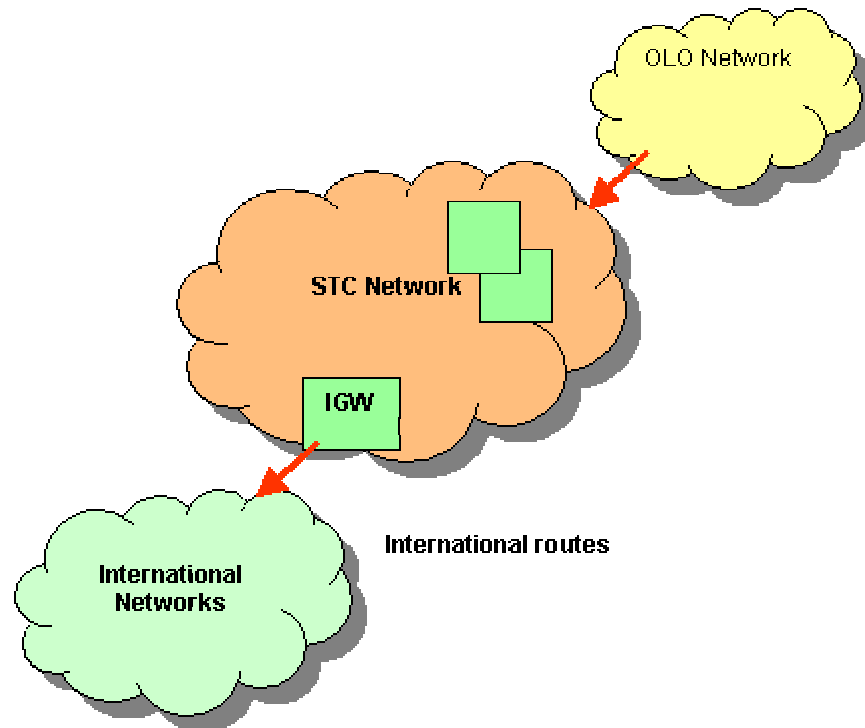

Figure1. Wholesale Outgoing International Voice Call Conveyance Services

3. Service Description

- 3.1 Subject to the provisions of this Schedule, STC shall only convey Wholesale Outgoing International Voice Call Conveyance Services for calls handed over from the Other Licensed Operator Network to a Third Party Network Operator's Network, if a rate for such a call is specified in Annex F (*Price List*).
- 3.2 STC shall convey Wholesale Outgoing International Voice Call Conveyance Services for calls, using the leading dialled digits "00" and handed over from the Other Licensed Operator's Network for delivery via an STC Service Node through the STC international gateway.
- 3.3 The Parties shall agree in advance all necessary technical requirements, including call set-up and clear down sequences, for the conveyance of calls pursuant to this Schedule.

- 3.4 STC shall not be obliged under this Schedule to make its Network suitable for the conveyance of ISDN International Outgoing Calls or to provide equipment to its customers enabling ISDN International Outgoing Calls.
- 3.5 STC shall provide Wholesale Outgoing International Voice Call Conveyance Services for the contract period and at the same standard and quality of service as it conveys similar calls originating in the STC network.
- 3.6 The Other Licensed Operator shall not hand over to STC and STC shall be under no obligation under this Schedule, to convey Wholesale Outgoing International Voice Call Conveyance Services for calls to those countries listed from time to time as being available only through the STC Operator.
- 3.7 Each Party shall locate and correct faults that occur in its Network which affect the conveyance of Wholesale Outgoing International Voice Call Conveyance Services traffic in accordance with such Party's normal engineering practices. For the avoidance of doubt, neither Party warrants that its Network is, or will be, free from faults.
- 3.8 In the event that a fault in the Other Licensed Operator's network becomes service affecting in the STC network, then STC reserves the right to suspend services to the Other Licensed Operator network until such time as the cause of the fault is rectified.

4. **Service Provisioning – Initial Procedure**

- 4.1 This Clause 4 applies where the Other Licensed Operator wishes to use the Wholesale Outgoing International Voice Call Conveyance Services provided by STC in respect of which the process in this Clause 4 has not already been undertaken.
- 4.2 The Other Licensed Operator shall notify STC by means of a request form as set out in Annex H (*Operations and Maintenance Manual*) if it requires the use of Wholesale Outgoing International Voice Call Conveyance Services.

- 4.3 STC shall acknowledge, in writing, receipt of the Other Licensed Operator's request under Clause 4.2 within five (5) Business Days.
- 4.4 Following receipt of a request under Clause 4.2, STC shall assess that request and notify the Other Licensed Operator within ten (10) Business Days of acknowledgement that either:
- a) The implementation of the request, in respect of the requested Wholesale Outgoing International Voice Call Conveyance Services, involves only network conditioning in STC's Network, in which case the negotiation period to agree technical interconnection arrangement prior to installation shall be thirty (30) Business Days; or
 - b) The implementation of the request in respect of the requested Wholesale Outgoing International Voice Call Conveyance Services involves work in addition to or as alternative to network conditioning in STC's Network, in which case negotiation period to agree the technical interconnection arrangement prior to installation shall be sixty (60) Business Days.
- 4.5 The Parties shall forthwith negotiate in good faith the requirements, implementation Charges and timetable for the use of the Wholesale Outgoing International Voice Call Conveyance Services provided by STC in accordance with the Other Licensed Operator's request under Clause 4.2 for the negotiation period notified in Clause 4.4. In the event that agreement is not reached either Party may commence the Dispute Resolution Procedure in accordance with Clause 19 of the Primary Document.
- 4.6 Where the Parties have reached an agreement, in accordance with 4.5 above, STC will commence implementation in accordance with the agreed timetable.
- 4.7 Nothing in this Clause 4 requires STC to perform any changes in its Network or to commence the supply of Wholesale Outgoing International Voice Call Conveyance Services until the Parties have completed all necessary Data Amendments required for that Wholesale Outgoing International Voice Call Conveyance Services and all network conditioning Charges in line with

Schedule (3A), Interconnect Links, and associated Price List, have been agreed to by the Other Licensed Operator.

4.8 The Other Licensed Operator may, at any time, request STC to cease supplying the Wholesale Outgoing International Voice Call Conveyance Services and STC shall cease supplying Wholesale Outgoing International Voice Call Conveyance Services as soon as practicable or at such later time as specified by the Other Licensed Operator in accordance with the terms and conditions specified in Clause 20 (Breach, Suspension and Termination) of the Primary Document.

5. **Forecasts**

5.1 Forecasts shall be supplied to STC by the Other Licensed Operator in accordance with Schedule 4 Clause 2.

6. **Charging**

6.1 Charging shall be in accordance with Schedule 4 Clause 3 and the rates published in Annex F (*Price List*).

7. **Billing Information**

7.1 Billing Verification shall be in accordance with Schedule 4 Clause 4.

8. **Routing**

8.1 The conveyance of Outgoing International Voice Calls shall be in accordance with the routing principles specified in Annex C (*Technical Information*).

SAUDI TELECOM COMPANY

Reference Interconnection Offer (RIO)

Annex G, Schedule 4C

**WHOLESALE INCOMING INTERNATIONAL
VOICE CALL CONVEYANCE**

Schedule (4C) Wholesale Incoming International Voice Call Conveyance

1. Service Definitions

<i>Interconnection Service</i>	<i>Definition</i>
Wholesale Incoming International Voice Call Conveyance Services:	An Incoming International Voice Call delivered to an STC IGW Exchange, thereafter switched by the STC Exchanges, before being handed over to the Other Licensed Operator Network.

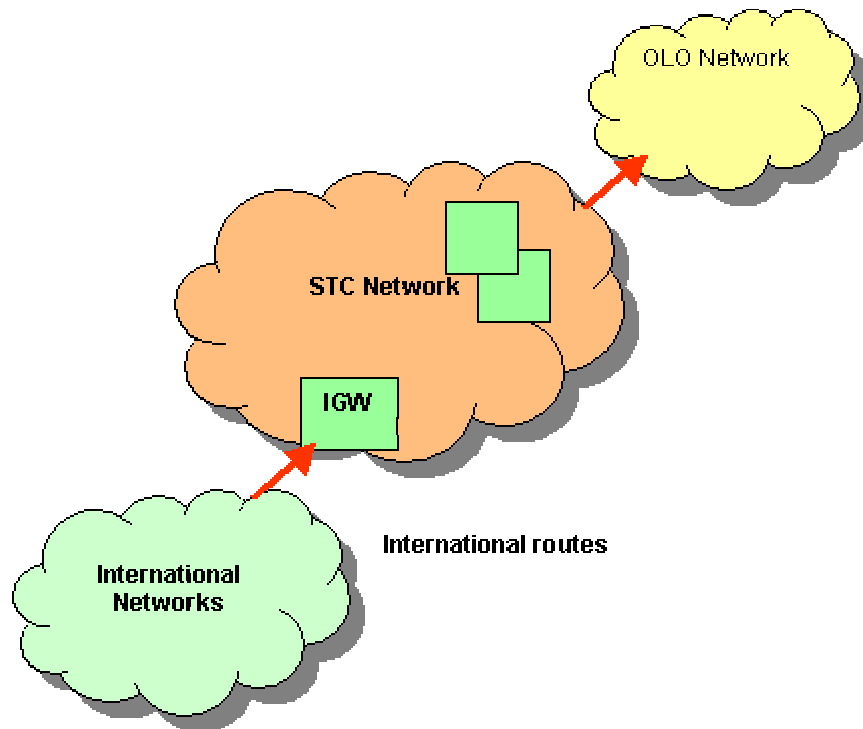

Figure 1: Wholesale Incoming International Voice Call Conveyance Services

2. Description of Service

- 2.1 Subject to the provisions of this Schedule, STC shall only provide Wholesale Incoming International Voice Call Conveyance services for calls handed over from an International Third Party Operator Network to STC for STC to

transmit to the Other Licensed Operator's Network, to number ranges allocated to that Other Licensed Operator by the CITC.

- 2.2 The Parties shall agree in advance all necessary technical requirements, including Call set-up and clear down sequences, for the conveyance of calls pursuant to this Schedule.
- 2.3 STC shall provide Wholesale Incoming International Voice Call Conveyance Services for the contract period and at the same standard and quality of service as it conveys similar calls incoming to the STC network.
- 2.4 STC shall not be obliged under this Schedule to make its Network suitable for the conveyance of ISDN International Incoming Calls or to provide equipment to its Customers enabling ISDN International Incoming Calls.
- 2.5 Each Party shall locate and correct faults that occur in its Network which affect the conveyance of Wholesale Incoming International Incoming Voice call traffic in accordance with such Party's normal engineering practices. For the avoidance of doubt, neither Party warrants that its Network is, or will be, free from faults.
- 2.6 In the event that a fault in the Other Licensed Operator's network becomes service affecting in the STC network, then STC reserves the right to suspend services to the Other Licensed Operator network until such time as the cause of the fault is rectified.

3. **Forecasts**

- 3.1 Forecasts shall be supplied to STC by the Other Licensed Operator in accordance with Schedule 4 Clause 2.

4. **Charging**

4.1 Charging shall be in accordance with Schedule 4 Clause 3 and the rates published in Annex F (*Price List*).

5. **Billing Information**

5.1 Billing Verification shall be in accordance with Schedule 4 Clause 4.

6. **Routing**

6.1 The conveyance of Incoming International Voice Calls shall be in accordance with the routing principles specified in Annex C (*Technical Information*).

SAUDI TELECOM COMPANY

Reference Interconnection Offer (RIO)

Annex G, Schedule 5

**COLLOCATION and
INFRASTRUCTURE SHARING**

Schedule (5) Collocation And Infrastructure Sharing

1. General

1.1 This Schedule sets out the terms and conditions under which STC will provide the Collocation and Infrastructure Sharing Services to the Other Licensed Operator.

1.2 This Schedule is comprised of the following sections:

Schedule (5A) – Interconnection Equipment Collocation Services

Schedule (5B) – Infrastructure Sharing Services

1.3 In this Schedule, a reference to a Clause or Annex, unless stated otherwise, is to a Clause or Annex of this Schedule.

SAUDI TELECOM COMPANY

Reference Interconnection Offer (RIO)

Annex G, Schedule 5A

**INTERCONNECTION EQUIPMENT
COLLOCATION SERVICES**

Schedule (5A) Interconnection Equipment Collocation Services

1. General

- 1.1 STC will supply Interconnection Equipment Collocation Service to the Other Licensed Operator in accordance with Clause 3 of the Primary Document in respect of the Services for which the process in Clause 4 of this Schedule (5A) has been followed.
- 1.2 For the avoidance of doubt, the process in Clause 4 of this Schedule (5A) must be initiated by the Other Licensed Operator if it wishes to acquire the Interconnection Equipment Collocation Services not previously covered by a request made under that Clause.
- 1.3 Notwithstanding the Interconnection of the STC Network and the Other Licensed Operator network, under this Schedule (5A), STC shall have no obligation to provide to the Other Licensed Operator Interconnection Equipment Collocation Services in respect of equipment not specifically required for the facilitation of Interconnection.
- 1.4 STC will only be required to provide Interconnection Equipment Collocation Services to the Other Licensed Operator to the extent that the Other Licensed Operator has complied with Annex H (*Operations and Maintenance Manual*) and this Schedule (5A).

2. Service Definition

<i>Interconnection Service</i>	<i>Definition</i>
Equipment Collocation Services	A service provided by STC offering Equipment space within an STC Operational Building which has been designated as a Service Node and suitable for hosting transmission equipment owned by the Other Licensed Operator for the sole purpose of Interconnection between the STC and Other Licensed Operator Networks.

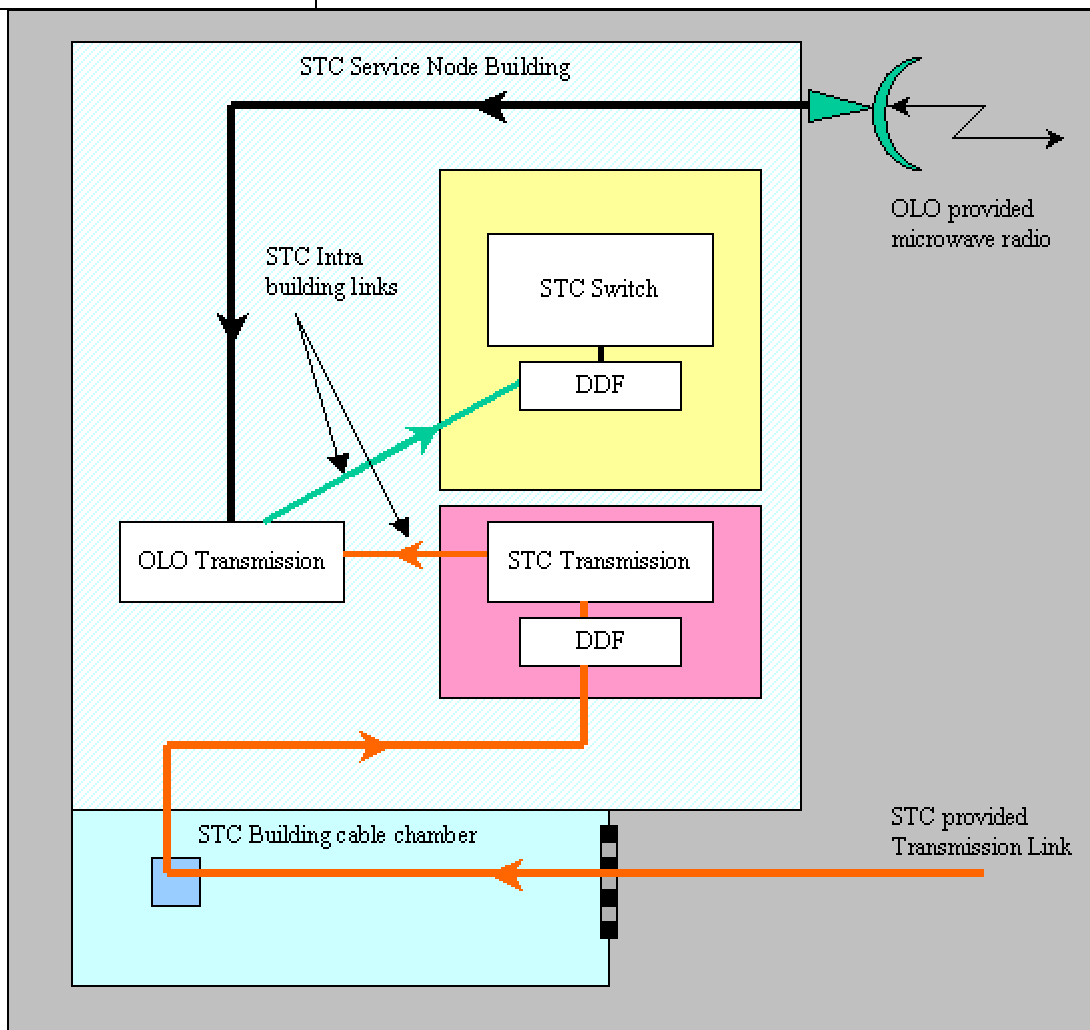

Figure 1: Equipment Collocation

3. **Description of Service**

- 3.1 Subject to the provisions of this Schedule, STC shall provide accommodation within specified STC Operational Buildings, which have been designated suitable for the installation and operation of Other Licensed Operator Transmission Equipment and where a Point of Interconnection (POI) is requested in accordance with Annex H (*Operations and Maintenance Manual*), only in respect of equipment specifically required to facilitate Interconnection of the STC and Other Licensed Operator networks.
- 3.2 STC shall provide Interconnection Equipment Collocation Services to the Other Licensed Operator for the contracted period at the same standard and quality of service as defined in a Service Level Agreement (SLA).
- 3.3 The Parties shall agree in advance all necessary technical requirements, including Footprint, Adequate Floor Loading, Power, Alarm Management, Air Conditioning, Fire Alarm and Suppression Systems, Security and Access arrangements.
- 3.4 STC will provide maintenance of the Collocation Facility in accordance with its standard building maintenance policy and procedures.
- 3.5 Except as provided in this Schedule, the Other Licensed Operator shall provide all installation materials and manpower needed for the installation of its Collocation Equipment.
- 3.6 Access to the Interconnection Equipment Collocation Services areas shall be restricted to authorized Other Licensed Operator personnel and/or their authorized nominated contractors for whom the Other Licensed Operator will assume full responsibility. Details of the processes for identify Authorised Personnel to STC are given in Annex H (*Operations and Maintenance Manual*).

- 3.7 STC will reserve the right of access to the Collocation Facility at any time in order to carry out planned and reactive maintenance of the building fabric, power and ancillary service systems.
- 3.8 Each Party shall locate and correct faults that occur in its Network which affect the provision of Interconnection Equipment Collocation Services in accordance with such Party's normal engineering practices. For the avoidance of doubt, neither Party warrants that its Network is, or will be, free from faults.
- 3.9 In the event that a fault in the Other Licensed Operator's network becomes service affecting in the STC network, then STC reserves the right to suspend services to the Other Licensed Operator network until such time as the cause of the fault is rectified.
- 3.10 For the use of the Interconnection Equipment Collocation Service, the Other Licensed Operator shall pay STC charges calculated in accordance with the rate for such Interconnection Equipment Collocation Services in accordance with Clause 5 of this Annex G.
- 3.11 For the purposes of this Schedule, STC may have regard to the following when assessing the availability of Collocation Space at a Collocation Site:
- STC's reasonably anticipated requirements in the next two (2) years for space at the Collocation Site for the provision to itself and its other Customers;
 - STC's reasonably anticipated requirements in the next two (2) years for space at the Collocation Site for operational and maintenance purposes;
 - Other Other Licensed Operator requirements (including those for operation and maintenance purposes) which have been ordered but not yet delivered or which have been provided;
 - Security and confidentiality requirements imposed on STC by Governmental Agencies;

- STC has plans to, or otherwise proposes to, decommission the Collocation Site.

3.12 The Other Licensed Operator must request space at a Collocation Site of a minimum of 1.44 square metres, which is the minimum space required to allow the installation of one (1) standard equipment rack or cabinet. The maximum available floor space will be determined on a site-by-site basis dependent upon the type of equipment to be installed and the results of a physical survey at that site.

3.13 The Collocation Facility will provide space for equipment racking with a standard height of 2200mm and footprint of 1800mm x 800mm for the installation of standard equipment racks and lockable metal equipment cabinets. All installed equipment must comply with current standards and regulations.

3.14 The Requesting Other Licensed Operator has no rights to assign in whole or in part the license in respect of the Collocation Space or to sub-let the Collocation Space at the Collocation Site.

3.15 The list of sites at which Interconnection Equipment Collocation Service can be requested is contained in Annex C (*Technical Information*) (STC Service Nodes Designated as Points of Interconnection). It should be noted that the availability of Interconnection Equipment Collocation Services at any of the Annex C listed locations is not guaranteed and will be subject to a physical survey carried out in accordance with Clause 4.4 a) of this Schedule.

4. **Service Provisioning**

4.1 This Clause 4 applies to all requests by the Other Licensed Operator to use the Interconnection Equipment Collocation Services provided by STC. For the avoidance of doubt this also includes requests for additional Interconnection Equipment Collocation Services as well as replacement, modification and rearrangement of existing collocated Interconnection Equipment.

- 4.2 The Other Licensed Operator shall notify STC of its request for the use of Interconnection Equipment Collocation Services by means of the request form set out in Annex H (*Operations and Maintenance Manual*) if it wishes to use the Interconnection Equipment Collocation Services.
- 4.3 STC shall acknowledge, in writing to the Other Licensed Operator's nominated representative, receipt of the Other Licensed Operator's request under Clause 4.2 within five (5) Business Days of its receipt.
- 4.4 Following receipt of a request under Clause 4.2, STC shall assess that request and notify the Other Licensed Operator within ten (10) Business Days of acknowledgement that either:
- a) The request has been provisionally accepted, on a non-binding basis subject to the satisfactory completion of an Interconnection Equipment Collocation Services Project Survey, in which case STC will:
- Where building work is required, carry out a detailed survey and produce a work Schedule and bill of quantities with costs
 - Agree planned work Schedule and costs with Other Licensed Operator
 - Accept the Other Licensed Operator order for collocation service
 - Execute building works
 - Confirm acceptance of out-turn costs by the Other Licensed Operator
 - Confirm acceptance of the collocation facility by Other Licensed Operator.
- b) The request has been rejected, in which case STC will provide the reasons for such rejection to the Other Licensed Operator. STC may reject a Collocation Request if any of the following applies:
- The Request Form for Interconnection Equipment Collocation Services is not in the prescribed form; or
 - The data contained in the Request form for Interconnection Equipment Collocation Services is incomplete; or

- The space requested is not within the limits prescribed by Clause 3.12 of this schedule;
- There is no available space at the Collocation Site as determined in accordance with Clause 3.11 of this schedule and the work required to create such space can be demonstrated to be practically and/or economically unviable.
- Acceptance of the Interconnection Equipment Collocation Services request will give rise to significant health, safety, technical or engineering issues.

4.5 STC shall recover the Collocation Request fee for the reasonable cost of processing the Request for Interconnection Equipment Collocation Services irrespective of the outcome of the Collocation Request.

5. **Charging**

5.1 Charges for each Interconnection Equipment Collocation Service will be available on request following the completion of the activities outlined in Clause 3.11 of this Schedule. The charges will include the following:

- a) One-off costs, which will include but not be limited to:
- A physical site survey of the specified building
 - Production of work Schedule and bill of quantities
 - Construction of dedicated collocation facility rooms
 - Refurbishing unused equipment areas
 - Installation of security systems
 - Provision of standard and/or enhanced ancillary support systems
 - Upgrading power supplies and engine sets, lighting, heating and ventilation systems
 - Providing external duct, inspection chambers and cables
 - Providing internal cables
 - Development and/or upgrading OSS

- Product development
 - Development of new processes, procedures and work practices
- b) Recurring Costs, which will include but not be limited to;
- Rental for the collocation space used
 - Maintenance of the collocation facilities and equipment areas
 - Maintenance of ancillary support systems
 - Power supplies, lighting, heating and ventilation systems
 - Maintenance of external plant and cables
 - Maintenance of internal cables
 - Order management
 - Security

SAUDI TELECOM COMPANY

Reference Interconnection Offer (RIO)

Annex G, Schedule 5B

**INFRASTRUCTURE SHARING :
TOWERS**

Schedule (5B) Infrastructure Sharing - Towers

1. General

- 1.1 STC shall supply Infrastructure Sharing Service to the Other Licensed Operator in accordance with Clause 3 of the Primary Document in respect of the Services for which the process in Clause 4 has been followed.
- 1.2 For the avoidance of doubt, the process in Clause 4 of this Schedule (5B) must be initiated by the Other Licensed Operator if it wishes to acquire the Infrastructure Sharing Service.
- 1.3 Notwithstanding the Interconnection of the STC Network and the Other Licensed Operator network, under this Schedule (3B), STC shall have no obligation to provide to the Other Licensed Operator Infrastructure Sharing Service in respect of equipment not specifically required for the facilitation transmission services.
- 1.4 STC shall only be required to provide Infrastructure Sharing Service to the Other Licensed Operator to the extent that the Other Licensed Operator has complied with Annex H (*Operations and Maintenance Manual*) and this Schedule (5B).

2. Service Definition

<i>Interconnection Service</i>	<i>Definition</i>
Infrastructure Sharing – Base Station Site and Towers	<p>A service provided by STC offering space and ancillary services on STC towers, to enable Other Licensed Operators to attach transmission equipment in order to self provide transmission services. Site sharing is only possible where it is technically and legally feasible to implement.</p> <p>Prices include: 3m x 3m space for a container; Civil</p>

	works, associated Power and access to the Tower for a maximum of 3 antennas (12 RTs).
--	---

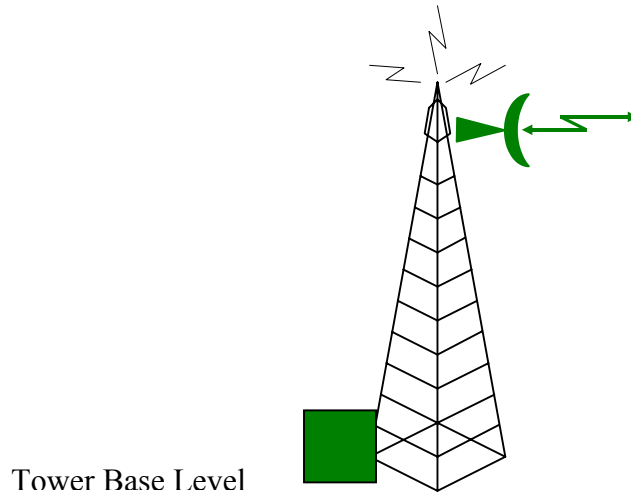

Figure 1. Infrastructure Sharing

3. Description of Service

- 3.1 Subject to the provisions of this Schedule, STC shall provide space and accommodation on and at STC Towers which are not located on the building rooftops and which have been designated suitable for the installation and operation of Other Licensed Operator Telecommunications Transmission Systems in accordance with Annex C (*Technical Information*). Generally, STC towers sited on building roof tops are not suitable for this service due to space, load bearing capacity and lease restrictions.
- 3.2 STC shall provide Infrastructure Sharing Services to the Other Licensed Operator for the contracted period at the same standard and quality of service as STC provides the same services internally.
- 3.3 The Parties shall agree in advance all necessary technical requirements, including but not limited to: Available Space, Tower Loading, Power, Security and Access arrangements.

-
- 3.4 Except as provided in this Schedule, the Other Licensed Operator shall provide all installation materials and manpower needed for the installation of its Equipment installed under this Schedule.
- 3.5 Access to the Infrastructure Sharing Services areas shall be restricted to authorized Other Licensed Operator personnel and/or their authorized nominated contractors for whom the Other Licensed Operator will assume full responsibility. The Other Licensed Operator shall be responsible for ensuring that the personnel working at heights on towers have received the appropriate training including working practices and training.
- 3.6 STC will reserve the right of access to the Infrastructure Sharing Service facilities at any time in order to carry out planned and reactive maintenance of the tower, power and ancillary service systems.
- 3.7 Each Party shall locate and correct faults that occur in its Network which affect the provision of Infrastructure Sharing Services in accordance with such Party's normal engineering practices. For the avoidance of doubt, neither Party warrants that its Network is, or will be, free from faults.
- 3.8 In the event that a fault in the Other Licensed Operator's network becomes service affecting in the STC network, then STC reserves the right to suspend services to the Other Licensed Operator network until such time as the cause of the fault is rectified.
- 3.9 For the use of the Infrastructure Sharing Service, the Other Licensed Operator shall pay STC charges calculated in accordance with the rate for such Infrastructure Sharing Services in accordance with Clause 5.
- 3.10 For the purposes of this Schedule, STC may have regard to the following when assessing the availability of Infrastructure Sharing space on individual towers:
- a) Tower loading;

- b) STC's reasonably anticipated requirements in the next two (2) years for space at the tower Site for the provision to itself and its other Customers;
- c) STC's reasonably anticipated requirements in the next two (2) years for space at the tower Site for operational and maintenance purposes;
- d) The Other Licensed Operator and other Third Party requirements (including those for operation and maintenance purposes) which have been ordered but not yet delivered or which have been provided;
- e) Radio spectrum interference with existing installed equipment;
- f) Security and confidentiality requirements imposed on STC by Governmental Agencies;
- g) STC has plans to, or otherwise proposes to, decommission the Tower.

3.11 The Other Licensed Operator must request the space and line of sight on a tower-by-tower basis. The availability of such facilities will be determined on a site-by-site basis dependent upon the results of a physical survey and the number of operators requesting Infrastructure Sharing Service at that tower site.

3.12 The Infrastructure Sharing Service will provide space for appropriate equipment for the purpose of providing microwave connectivity to be located at the base of the tower. All Other Licensed Operator equipment must be installed in suitable secure and weatherproof containers. STC will take no responsibility for Other Licensed Operator equipment installed at Infrastructure Sharing sites. All installed equipment must comply with current standards and regulations.

3.13 The Requesting Other Licensed Operator has no rights to assign its rights in respect of sub-letting the Infrastructure Sharing space at any tower Site.

3.14 The Requesting Other Licensed Operator has no rights to transfer the Infrastructure Sharing Service space at the Collocation Site.

4. **Service Provisioning**

4.1 This Clause 4 applies to all requests by the Other Licensed Operator to use the Infrastructure Sharing Services provided by STC. For the avoidance of doubt this also includes requests for additional Infrastructure Sharing Services as well as replacement, modification and rearrangement of existing Infrastructure Sharing Services.

4.2 The Other Licensed Operator shall notify STC of its request for the use of Infrastructure Sharing Services by means of the request form set out in Annex H (*Operations and Maintenance Manual*) if it wishes to use the Infrastructure Sharing Services.

4.3 STC shall acknowledge, in writing to the Other Licensed Operator's nominated representative, receipt of the Other Licensed Operator's request under Clause 4.2 within five (5) Business Days of its receipt.

4.4 Following receipt of a request under Clause 4.2, STC shall assess that request and notify the Other Licensed Operator within ten (10) Business Days of acknowledgement that either:

- a) The request has been provisionally accepted on a non-binding basis subject to the satisfactory completion of an Infrastructure Sharing Services Project Survey. In which case STC will:
- Where building work is required STC will carry out a detailed survey and produce a work Schedule and bill of quantities with costs.
 - Agree planned work Schedule and costs with Other Licensed Operator.
 - Accept the Other Licensed Operator order for Infrastructure Sharing Services.
 - Execute building works.
 - Confirm acceptance of out-turn costs by the Other Licensed Operator.

- Confirm acceptance of the collocation facility by Other Licensed Operator.
- b) The request has been rejected, in which case STC will provide the reasons for such rejection to the Other Licensed Operator. STC may reject a Infrastructure Sharing Services if:
- The Request Form for Infrastructure Sharing Services is not in the prescribed form; or
 - The data contained in the Request form for Infrastructure Sharing Services is incomplete; or
 - There is no available space at the Collocation Site as determined in accordance with Clause 3.10 and the work required to create such space can be demonstrated to be practically and/or economically unviable.
 - Acceptance of the Infrastructure Sharing Services request will give rise to significant health, safety, technical or engineering issues.

4.5 STC shall recover the Infrastructure Sharing Request fee for the reasonable cost of processing the Request for Infrastructure Sharing Services irrespective of the outcome of the Infrastructure Sharing Request.

5. **Charging**

5.1 Charges for each Infrastructure Sharing Service will be available on request following the completion of the activities outlined in Clause 3.10 of this Schedule. The charges will include:

- a) One-off costs, including but not limited to:
- A physical site survey of the specified location
 - Production of work Schedule and bill of quantities
 - Construction of dedicated Infrastructure Sharing facility
 - Installation of security systems
 - Provision of standard and/or enhanced ancillary support systems

- Upgrading power supplies and engine sets, lighting, heating and ventilation systems
- Product development
- Development of new processes, procedures and work practices

b) Recurring Costs, including but not limited to:

- Rental for the Infrastructure Sharing space used
- Maintenance of the Infrastructure Sharing facilities and equipment areas
- Maintenance of ancillary support systems
- Power supplies, lighting, heating and ventilation systems
- Order management
- Security

SAUDI TELECOM COMPANY

Reference Interconnection Offer (RIO)

Annex G, Schedule 6

CALLS TO DIRECTORY ENQUIRIES

Schedule (6) Calls To Directory Enquiries

1. General

- 1.1 STC shall supply the Calls to Directory Enquiry Service in accordance with Clause 3 of the Primary Document in respect of the Call Types for which the process in Clause 4 has been followed.
- 1.2 For the avoidance of doubt, the process in Clause 4 must be initiated by the Other Licensed Operator if it wishes to acquire the Calls to Directory Enquiries Service in respect of calls from the Other Licensed Operator network not previously covered by a request made under that Clause.
- 1.3 STC shall only be required to provide the Calls to Directory Enquiry Service to the Other Licensed Operator to the extent that the Other Licensed Operator has complied with Annex H (*Operations and Maintenance Manual*) and this Schedule (6).

2. Service Definition

<i>Interconnection Service</i>	<i>Definition</i>
Calls to Directory Enquiry Service	A Call, dialled by a 3 digit number, handed over from the Other Licensed Operator Network to the STC Network, routed to an STC Call Centre and answered by STC operators with access to the STC Directory System. STC will provide listed telephone numbers only of named subscribers within the Kingdom of Saudi Arabia from the database.

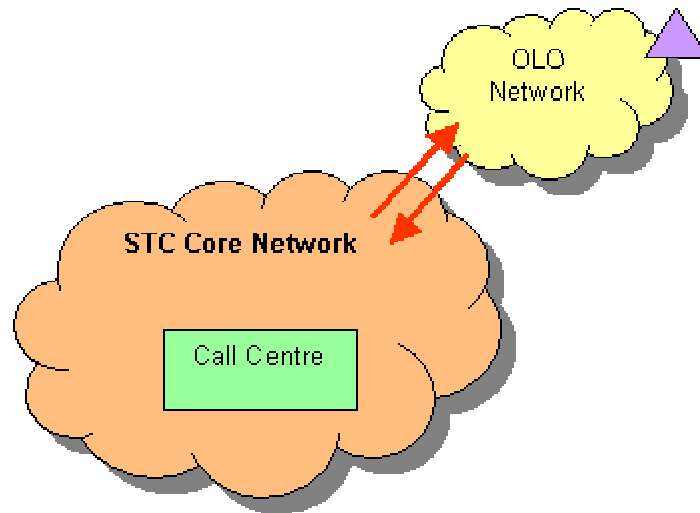

Figure 1: Calls to Directory Enquiries

3. Description of Service

- 3.1 STC shall convey calls to Directory Enquiry Services for the contracted period at the same standard and quality of service as STC conveys similar calls originated on the STC network.
- 3.2 The Parties shall agree in advance all necessary technical requirements, including call set-up and clear down sequences, for the conveyance of calls pursuant to this Schedule.
- 3.3 Each Party shall locate and correct faults that occur in its Network which affect the conveyance of Voice Call Termination traffic in accordance with such Party's normal engineering practices. For the avoidance of doubt, neither Party warrants that its Network is, or will be, free from faults.
- 3.4 In the event that a fault in the Other Licensed Operator's network becomes service affecting in the STC network, then STC reserves the right to suspend services to the Other Licensed Operator network until such time as the cause of the fault is rectified.

3.5 For the provision of conveyance of Calls to Directory Enquiry Services the Other Licensed Operator shall pay STC a charge calculated in accordance with the rate for such a Call specified from time to time in Annex F (*Price List*).

4. **Service Provisioning**

4.1 This Clause 4 applies where the Other Licensed Operator wishes to use the Calls to Directory Enquiry Services in respect of which the process in this Clause 4 has not already been undertaken.

4.2 The Other Licensed Operator shall notify STC of its request for the use of Calls to Directory Enquiry Services by means of the request form set out in Annex H (*Operations and Maintenance Manual*) if it wishes to use the Calls to Directory Enquiry Services.

4.3 STC shall acknowledge, in writing to the Other Licensed Operator's nominated representative, receipt of the Other Licensed Operator's request under Clause 4.2 within five (5) Business Days of its receipt.

4.4 Following receipt of a request under Clause 4.2, STC shall assess that request and notify the Other Licensed Operator within ten (10) Business Days of acknowledgement that either:

- a) The implementation of the request, in respect of the requested Calls to Directory Enquiry Services, involves only network conditioning in STC's Network, in which case the negotiation period to agree technical interconnection arrangement prior to installation shall be thirty (30) Business Days; or
- b) The implementation of the request in respect of the requested Calls to Directory Enquiry Services involves work in addition to or as alternative to network conditioning in STC's Network, in which case the negotiation period to agree technical interconnection arrangement prior to installation shall be sixty (60) Business Days.

- 4.5 The Parties shall forthwith negotiate in good faith the technical requirements and timetable for the use of the Calls to Directory Enquiry Services in accordance with the Other Licensed Operator's request under Clause 4.2 for the negotiation period specified in Clause 4.4. In the event that agreement is not reached either Party may commence the Dispute Resolution Procedure in accordance with Clause 19 of the Primary Document.
- 4.6 Where the Parties have reached an agreement, in accordance with Clause 4.4 above, STC will commence implementation in accordance with the agreed timetable as per Clause 4.5.
- 4.7 Nothing in this Clause 4 requires STC to perform any changes in its Network or to commence the supply of Calls to Directory Enquiry Services until the Parties have completed all necessary Data Amendments required for Calls to Directory Enquiry Services and all network conditioning Charges in line with Schedule (3A), Interconnect Links, and associated Price list have been agreed to by the Other Licensed Operator.
- 4.8 The Other Licensed Operator may, at any time, request STC to cease supplying the Calls to Directory Enquiry Services and STC shall cease supplying the Calls to Directory Enquiry Services as soon as practicable or at such later time as specified by the Other Licensed Operator in accordance with the terms and conditions specified in Clause 20 (Breach, Suspension and Termination) of the Primary Document.

5. **Number Range Activation**

- 5.1 Notice and response times for number range activation shall be in accordance with Schedule 2 Clause 2 of this Annex G.

6. **Forecasts**

- 6.1 Forecasts shall be supplied to STC by the Other Licensed Operator in accordance with Schedule 2 Clause 3 of this Annex G.

7. **Charging**

7.1 Charging shall be in accordance with Schedule 2 Clause 4.

8. **Billing Information**

8.1 Billing Verification shall be in accordance with Schedule 2 Clause 5.

9. **Routing**

9.1 The conveyance of Calls to Directory Enquiries shall be in accordance with the routing principles specified in Annex C (*Technical Information*).

SAUDI TELECOM COMPANY

Reference Interconnection Offer (RIO)

Annex G, Schedule 7

CALLS TO EMERGENCY SERVICES

Schedule (7) Calls To Emergency Services

1. General

- 1.1 STC shall supply Calls to Emergency Services in accordance with Clause 3 of the Primary Document in respect of the call types for which the process in Clause 4 of this Schedule (7) has been followed.
- 1.2 For the avoidance of doubt, the process in Clause 4 must be initiated by the Other Licensed Operator if it wishes to acquire Calls to Emergency Services in respect of Calls from the Other Licensed Operator network not previously covered by a request made under that Clause.
- 1.3 STC shall only be required to provide Calls to Emergency Services to the Other Licensed Operator to the extent that the Other Licensed Operator has complied with Annex H (*Operations and Maintenance Manual*) and this Schedule 7.

2. Service Definition

<i>Interconnection Service</i>	<i>Definition</i>
Calls to Emergency Services	A call, initially dialled by a 3 digit number, handed over from the Other Licensed Operator Network to the STC Network, initially switched by STC's Exchanges, and passed to an STC LE for delivery to a STC Network Termination Point within that LE or parented RU which is the location of the respective Emergency Service call centre.

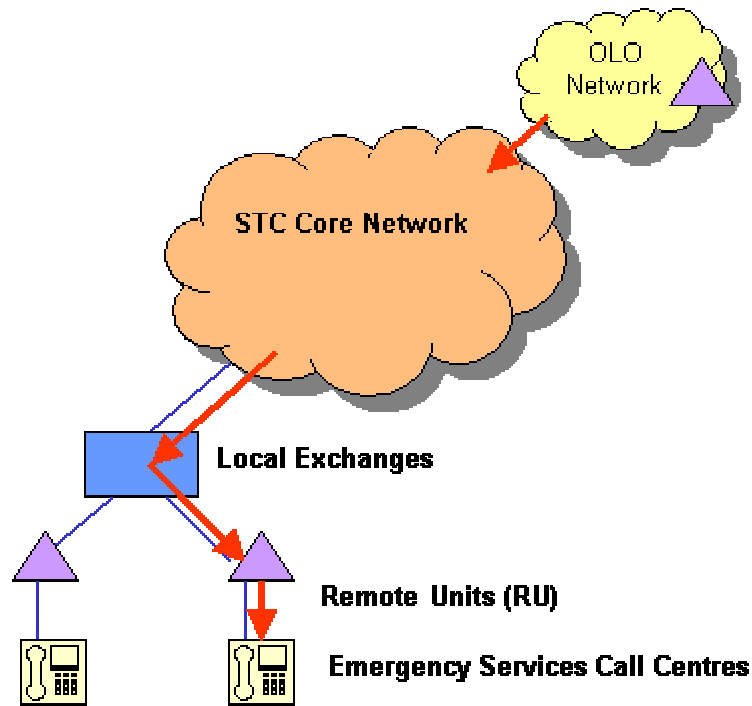

Figure 1: Calls to Emergency Services

3. Description of Service

- 3.1 STC shall convey calls to Emergency Services for the contracted period at the same standard and quality of service as STC conveys similar calls originated on the STC network.
- 3.2 The Parties shall agree in advance all necessary technical requirements, including call set-up and clear down sequences, for the conveyance of calls pursuant to this Schedule.
- 3.3 Each Party shall locate and correct faults that occur in its Network which affect the conveyance of Voice Call Termination traffic in accordance with such Party's normal engineering practices. For the avoidance of doubt, neither Party warrants that its Network is, or will be, free from faults.
- 3.4 In the event that a fault in the Other Licensed Operator's network becomes service affecting in the STC network, then STC reserves the right to suspend services to the Other Licensed Operator network until such time as the cause of the fault is rectified.

3.5 For the provision of conveyance Calls to Emergency Services the Other Licensed Operator shall pay STC a charge calculated in accordance with the rate for such a call specified from time to time in Annex F (*Price List*).

4. **Service Provisioning**

4.1 This Clause 4 applies where the Other Licensed Operator wishes to use the Calls to Emergency Services in respect of which the process in this Clause 4 has not already been undertaken.

4.2 The Other Licensed Operator shall notify STC of its request for the use of Calls to Emergency Services by means of the request form set out in Annex H (*Operations and Maintenance Manual*) if it wishes to use the Calls to Emergency Services.

4.3 STC shall acknowledge, in writing to the Other Licensed Operator's nominated representative, receipt of the Other Licensed Operator's request under Clause 4.2 within five (5) Business Days of its receipt.

4.4 Following receipt of a request under Clause 4.2, STC shall assess that request and notify the Other Licensed Operator within ten (10) Business Days of acknowledgement that either:

- a) The implementation of the request, in respect of the requested Calls Emergency Services, involves only network conditioning in STC's Network, in which case the negotiation period to agree technical interconnection arrangement prior to installation shall be thirty (30) Business Days; or
- b) The implementation of the request in respect of the requested Calls to Emergency Services involves work in addition to or as alternative to network conditioning in STC's Network, in which case the negotiation period to agree technical interconnection arrangement prior to installation shall be sixty (60) Business Days.

- 4.5 The Parties shall forthwith negotiate in good faith the technical requirements and timetable for the use of the Calls to Emergency Services in accordance with the Other Licensed Operator's request under Clause 4.2 for the negotiation period specified in Clause 4.4. In the event that agreement is not reached either Party may commence the Dispute Resolution Procedure in accordance with Clause 19 of the Primary Document.
- 4.6 Where the Parties have reached an agreement, in accordance with Clause 4.4 above, STC will commence implementation in accordance with the agreed timetable as per Clause 4.5.
- 4.7 Nothing in this Clause 4 requires STC to perform any changes in its Network or to commence the supply of Calls to Emergency Services until the Parties have completed all necessary Data Amendments required for Calls to Emergency Services and all network conditioning Charges in line with Schedule (3A), Interconnect Links, and associated Price list have been agreed to by the Other Licensed Operator.
- 4.8 The Other Licensed Operator may, at any time, request STC to cease supplying the Calls to Emergency Services and STC shall cease supplying the Calls to Emergency Services as soon as practicable or at such later time as specified by the Other Licensed Operator in accordance with the terms and conditions specified in Clause 20 (Breach, Suspension and Termination) of the Primary Document.

5. **Number Range Activation**

- 5.1 Notice and response times for number range activation shall be in accordance with Schedule 2 Clause 2.

6. **Forecasts**

- 6.1 Forecasts shall be supplied to STC by the Other Licensed Operator in accordance with Schedule 2 Clause 3.

7. **Charging**

7.1 Charging shall be in accordance with Schedule 2 Clause 4.

8. **Billing Information**

8.1 Billing Verification shall be in accordance with Schedule 2 Clause 5.

9. **Routing**

9.1 The conveyance of Calls to Emergency Services shall be in accordance with the routing principles specified in Annex C (*Technical Information*).

SAUDI TELECOM COMPANY

Reference Interconnection Offer (RIO)

Annex G, Schedule 8

Short Messaging Services

Schedule (8) Short Messaging Services (SMS)

1. General

- 1.1 SMS is a messaging system representing an alphanumeric sequence of text, which uses the CCITT No. 7 MAP protocol and generally conforms to GSM Technical Specs of GSM 03.40, GSM 04.11 and GSM 09.02 (as amended from time to time).
- 1.2 STC shall supply Short Messaging Services (SMS) Interconnection services in accordance with Clause 3 of the Primary Document in respect of the message types for which the process in Clause 4 of this Schedule (8) has been followed.
- 1.3 For the avoidance of doubt, the process in Clause 4 must be initiated by the Other Licensed Mobile Operator if it wishes to acquire SMS Interconnection Services in respect of Text Messages from the Other Licensed Mobile Operator network not previously covered by a request made under that Clause.
- 1.4 STC shall only be required to provide SMS Interconnection to the Other Licensed Mobile Operator to the extent that the Other Licensed Mobile Operator has complied with Annex H (*Operations and Maintenance Manual*) and this Schedule 8.

2. Service Definition

<i>Interconnection Service offered by STC</i>	<i>Definition</i>
Short Message Services (SMS) Termination at STC	Messages sent to mobile phones or other devices belonging to customers of STC and originated from mobile phones or other devices belonging to customers of the Other Licensed Mobile Operator.

<i>Interconnection Service offered by STC (continued)</i>	<i>Definition</i>
<p align="center">Confirmation of SMS received at STC</p>	<p>A message originated by mobile phones or other devices belonging to customers of STC to confirm reception of an SMS message that was originated from mobile phones or other devices belonging to customers of Other Licensed Mobile Operator, for which the Other Licensed Mobile Operator customer requested such an SMS confirmation message.</p>

3. Description of Service

- 3.1 STC shall convey Short Message Services for the contracted period at the same standard and quality of service as STC conveys similar SMSs within the STC network.
- 3.2 The Parties shall agree in advance all necessary technical requirements, including protocol and sequences, for the conveyance of SMS pursuant to this clause 3 of this Schedule.
- 3.3 Each Party shall locate and correct faults that occur in its Network which affect the conveyance of SMS traffic in accordance with such Party's normal engineering practices. For the avoidance of doubt, neither Party warrants that its Network is, or will be, free from faults.
- 3.4 In the event that a fault in the Other Licensed Mobile Operator's network becomes service affecting in the STC network, then STC reserves the right to suspend services to the Other Licensed Mobile Operator network until such time as the cause of the fault is rectified.

- 3.5 For the provision of conveyance of SMS the Other Licensed Mobile Operator shall pay STC a charge calculated in accordance with the rate for such a Message specified from time to time in Annex F (*Price List*).
- 3.6 The Principle of SMS Hand-over shall be that an SMS shall be handed over by the Originating Party from the Originating Party's Network to the Terminating Party's Network at a Short Message Service Service Delivery Point (SMSSDP) in the Terminating Party's premises agreed to by the parties, having regard, without limitation, to good network design principles and practices.
- 3.7 Spamming
- c) The parties acknowledge that the transmission of unsolicited SMSs from a party's Network to a significant number of customers on the other party's Network in a manner which is likely to annoy the recipient customers is undesirable. Each party shall use its reasonable endeavours to discourage the transmission of unsolicited SMSs.
 - d) Each party shall have the right to monitor and possibly block spamming that could adversely affect their network or customers.
4. **Service Provisioning**
- 4.1 This Clause 4 applies where the Other Licensed Mobile Operator wishes to use the SMS Interconnection service in respect of which the process in this Clause 4 has not already been undertaken.
- 4.2 The Other Licensed Mobile Operator shall notify STC of its request for the use of SMS Interconnection by means of the request form set out in Annex H (*Operations and Maintenance Manual*) if it wishes to use the SMS Interconnection Service.
- 4.3 STC shall acknowledge, in writing to the Other Licensed Mobile Operator's nominated representative, receipt of the Other Licensed Mobile Operator's request under Clause 4.2 within five (5) Business Days of its receipt.

- 4.4 Following receipt of a request under Clause 4.2, STC shall assess that request and notify the Other Licensed Mobile Operator within ten (10) Business Days of acknowledgement that either:
- e) The implementation of the request, in respect of the requested SMS Interconnection service, involves only network conditioning in STC's Network, in which case the negotiation period to agree technical interconnection arrangement prior to installation shall be thirty (30) Business Days; or
 - f) The implementation of the request in respect of the requested SMS Interconnection service involves work in addition to or as alternative to network conditioning in STC's Network, in which case the negotiation period to agree technical interconnection arrangements prior to installation shall be sixty (60) Business Days.
- 4.5 The Parties shall forthwith negotiate in good faith the technical requirements and timetable for the use of the SMS Interconnection service in accordance with the Other Licensed Mobile Operator's request under Clause 4.2 for the negotiation period specified in Clause 4.4. In the event that agreement is not reached either Party may commence the Dispute Resolution Procedure in accordance with Clause 19 of the Primary Document.
- 4.6 Where the Parties have reached an agreement, in accordance with Clause 4.5 above, STC will commence implementation in accordance with the agreed timetable as per Clause 4.4.
- 4.7 Nothing in this Clause 4 requires STC to perform any changes in its Network or to commence the supply of the SMS Interconnection service until the Parties have completed all necessary Data Amendments required for SMS Interconnection and all network conditioning Charges in line with Schedule (3A), Interconnect Links, and associated Price List have been agreed to by the Other Licensed Mobile Operator.

- 4.8 The Other Licensed Mobile Operator may, at any time, request STC to cease supplying the SMS Interconnection service and STC shall cease supplying the SMS Interconnection service as soon as practicable or at such later time as specified by the Other Licensed Mobile Operator in accordance with the terms and conditions specified in Clause 20 (Breach, Suspension and Termination) of the Primary Document.
- 4.9 If either party considers that new Signalling Links are required to be provided and such Links have not been forecasted then the party identifying the requirement shall notify the other of the number of Signalling Links that it believes are required and the dates by which it believes that those Signalling Links are required. The requirement will be agreed by the Technical and Commercial Review Committee and provisioned in accordance with Clause 4.10.
- 4.10 Subject to the remainder of this clause 4, each party will be responsible for provisioning every alternate (2nd) both-way Signalling Link to enable the delivery of SMS traffic between the two parties' Networks. To illustrate the responsibility of each party to provision every alternate Signalling Link, the Other Licensed Mobile Operator provisions the first Signalling Link, STC provisions the second Signalling Link, and the Other Licensed Mobile Operator provisions the third Signalling Link and so on. This should take into account ITU recommended signalling load balancing principles in the choice of the number of links in the final signalling link sets.
5. **Numbering**
- 5.1 The Originating Party shall transmit an accurate A-number with each SMS handed over to the Terminating Party so that the Terminating Party's customer is able to immediately reply to that SMS from the Originating Party's customer.

- 5.2 For the avoidance of doubt, the Originating Party shall not have complied with clause 5.1 if it transmits a modified A-number to the Terminating Party of the SMS.
- 5.3 For the avoidance of doubt, in respect of any SMS handed over from the Originating Party's Network to the Terminating Party's Network, there shall be no charge to the Terminating Party for the provision by the Originating Party of any number information provided by the Originating Party, including the A-number.
- 5.4 The addresses of SMSSDP's of the two operators shall be listed as shown in the table below and included in the joint network plan.

STC's Short Message Services Service Delivery Points (SMSSDP)	Other Licensed Mobile Operator's Short Message Services Service Delivery Points (SMSSDP)

6. Forecasts

- 6.1 Forecasts shall be supplied in accordance with the processes detailed in the *Annex E – Forecasting*.
- 6.2 If the other party agrees with the number of Signalling Links forecast by the first party in accordance with clause *Annex E - Forecasting* and the timing for the provision of those Signalling Links, then each party shall use its reasonable endeavours to provision every alternate Signalling Link in accordance with clause 4.10 by the dates agreed between the parties.

- 6.3 The parties agree to provide to each other forecasts of SMS traffic in accordance with the procedures detailed in Annex E (*Forecasting*). The content of the traffic forecasts will cover:
- g) the average number of SMS per day and the peak number of SMS per busy hour; and
 - h) the number of Signalling Links required, including the speed of each Signalling Link requested by the forecasting party.
7. **Charging**
- 7.1 STC will for those Terminating SMSs collect a Call Data Record (CDR) for each individual SMS and process such records in accordance with this Clause 7.
- 7.2 The CDRs collected by STC in accordance with this Clause shall be the source of the data used by STC for Bill Verification as per this Clause 8 and to invoice for the SMS Interconnection Services provided under this Schedule.
- 7.3 The calculation of Charges for the SMS Termination Services will be based on the number and type of SMSs in accordance with the applicable rates set out in Annex F (*Price List*).
- 7.4 In case an arrangement is implemented with regards to the SMS confirmation service, the applicable rates set out in Annex F (*Price List*) will apply.
- 7.5 For the avoidance of doubt, an SMS handed over from the Originating Party to the Terminating Party shall not be a Chargeable SMS where that SMS is handed over to the Terminating Party during the period of any suspension of the SMS Interconnection Service under Clause 20 of the Primary Document or Clause 7.6.
- 7.6 In line with sub-Clause 3.7, STC may, without liability, immediately suspend the SMS Service made available and provided to the other party in relation to

SMSs that are sent to particular Network Numbers of STC (e.g. circumstances if more 500 SMS are sent to individual numbers during any 24 hour period).

7.7 Such circumstances indicted in Clause 7.6 above, or any other reasonable criteria, shall be communicated to the other party with 24 hours notice.

8. **Billing Information**

8.1 Billing Verification shall be in accordance with Annex G, Schedule 2 Clause 5.

9. **Routing**

9.1 The conveyance of SMS shall be in accordance with the signalling routing principles to be agreed upon between STC and the Other Licensed Mobile Operator. Such agreement will form part of the Network Plan.

SAUDI TELECOM COMPANY

Reference Interconnection Offer (RIO)

Annex G, Schedule 9

**WHOLESALE INTERNATIONAL
PRIVATE LEASED CIRCUIT SERVICES**

Schedule (9) Wholesale International Private Leased Circuit Service

1. General

- 1.1 STC will supply the Wholesale International Private Leased Circuit Service (IPLC) to the Other Licensed Operator in accordance with Clause 3 of the Primary Document in respect of the Services for which the process in Clause 4 of this Schedule (9) has been followed.
- 1.2 For the avoidance of doubt, the process in Clause 4 of this Schedule (9) must be initiated by the Other Licensed Operator if it wishes to acquire the Wholesale International Private Leased Circuit Services not previously covered by a request made under that Clause.
- 1.3 Notwithstanding the Interconnection of STC's Network and the Other Licensed Operator's network, STC shall have no obligation to provide services other than those specified for the provision of Wholesale International Leased Line Services within standard delivery lead-times where appropriate, (extended lead-times apply where plant is not available) and subject to standard engineering and commercial principles.
- 1.4 STC will only be required to provide the Wholesale International Private Leased Circuit Service to the Other Licensed Operator to the extent that the Other Licensed Operator has complied with Annex H (*Operations and Maintenance Manual*) and this Schedule (9).

2. Service Definition

<i>Interconnection Service</i>	<i>Definition</i>
<p align="center">Wholesale International Private Leased Circuit Service</p>	<p>A service where STC provides an International Private Leased Data Circuit (IPLC) between two fixed points via its National / International Transmission infrastructure, with one end of the circuit located on the Other Licensed Operator's property/site in KSA and with the other end of the circuit located in a foreign country as requested by the OLO via the Network of the distant International Operator who is STC's counterpart. (STC will coordinate with the distant International Operator for establishing the other half circuit for which the OLO will be responsible for all applicable payments.)</p>

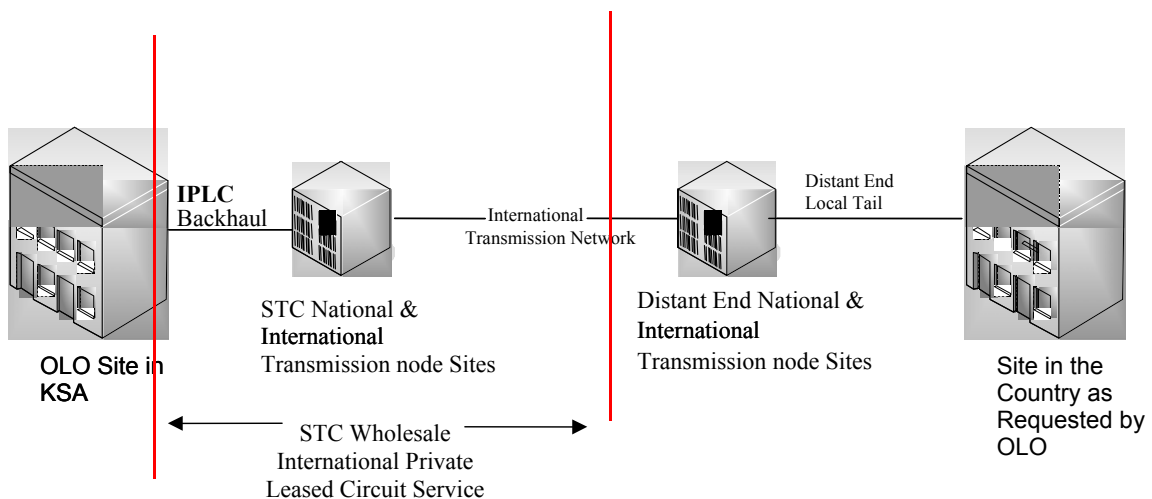

Figure 2: Wholesale International Private Leased Circuit Service

3. **Description of Service**

- 3.1 Subject to the provisions of this Schedule, STC shall provide the Wholesale International Private Leased Circuit Service between the Other Licensed Operator's site in KSA and the site that has been requested by OLO in the country to where the International Wholesale Private Leased Circuit service has been requested.
- 3.2 STC shall provide the Wholesale International Private Leased Circuit Service for the Other Licensed Operator for the contract period and at the same standard and quality of service as it provides for similar links to other clients.
- 3.3 The Parties shall agree in advance all necessary technical requirements, including physical circuit installation and operation for the provision of the Wholesale International Private Leased Circuit Service pursuant to this Schedule (9).
- 3.4 Each Party shall locate and correct faults that occur in its Network and which affect the performance of the Wholesale International Private Leased Circuit Service in accordance with each Party's normal engineering practices. For the avoidance of doubt, neither Party warrants that its Network is, or will be, free from faults.
- 3.5 The provision of the Wholesale International Private Leased Circuit Service shall be in accordance with the STC Transmission principles specified in Annex C (*Technical Information*).
- 3.6 The Wholesale International Private Leased Circuits Service will be provided using agreed appropriate technology including both fixed and wireless systems.
- 3.7 The IPLC service can be provided by STC from any place in the Kingdom and the price of the IPLC circuit will vary depending on the location of the OLO

property/site. The destinations across the Kingdom have been divided into three categories with prices indicated accordingly in Annex F (*Price List*).

- 3.8 For the provision of each Wholesale International Private Leased Circuit Service, the Other Licensed Operator shall pay STC charges in accordance with the rate for such a Link as specified from time to time in Annex F (*Price List*).
- 3.9 The provision of the Wholesale International Private Leased Circuit Service is not available to all the International destinations. The OLO intending to order this Service should contact the STC Wholesale Business Unit in order to obtain information as to which International Destinations the Wholesale IPLC service is available.
- 3.10 It is also important for the OLO to know that only one portion of the Wholesale IPLC service is provided by STC. Some elements of the service, including the “remote tail end”, and in many cases the international transmission, is delivered by a third party network. STC is therefore not able to offer end-to-end quality of service undertakings other than those obtained through Service Level Agreements with other operators.

4. **Service Provisioning – Initial Procedure**

- 4.1 This Clause 4 applies whenever the Other Licensed Operator wishes to use the Wholesale International Private Leased Circuit Service provided by STC in respect of which the process in this Clause 4 has not already been undertaken.
- 4.2 The Other Licensed Operator shall notify STC by means of the request form set out in Annex H (*Operations and Maintenance Manual*) if it requests the use of a Wholesale International Private Leased Circuit Service.
- 4.3 STC shall acknowledge, in writing, receipt of the Other Licensed Operator’s request under Clause 4.2 within five (5) Business Days of its receipt.

- 4.4 Following receipt of a request under Clause 4.2, STC shall assess that request and notify the Other Licensed Operator within ten (10) Business Days that either:
- a) The implementation of the request in respect of the requested Wholesale International Private Leased Circuit Service involves only network conditioning in STC's Network, in which case the negotiation period shall be thirty (30) Business Days; or
 - b) The implementation of the request in respect of the requested Wholesale International Private Leased Circuit Service involves work in addition to or as alternative to network conditioning in STC's Network, in which case the negotiation period shall be sixty (60) Business Days, or
 - c) Facilities are unavailable.
- 4.5 The Parties shall forthwith negotiate in good faith the requirements, implementation charges and timetable for the use of the Wholesale International Private Leased Circuit Service provided by STC in accordance with the Other Licensed Operator's request under Clause 4.2 for the negotiation period specified in Clause 4.4 (a) and (b) failing which either Party may commence the Dispute Resolution Procedure as defined in Clause 19 of the Primary Document.
- 4.6 Where the Parties have reached an agreement, in accordance with 4.4 (a) and (b) above, STC will commence implementation in accordance with the agreed timetable and in line with the delivery schedules contained in Annex I (*Quality of Service Measure*).
- 4.7 Nothing in this Clause 4 requires STC to perform any changes in its Network or to commence the supply of the Wholesale International Private Leased Circuit Service until the Parties have completed the preparation for that International Private Leased Circuit Service and all network conditioning Charges have been agreed to by the Other Licensed Operator.

4.8 The Other Licensed Operator may, at any time, request STC to cease supplying the Wholesale International Private Leased Circuit Service and STC shall cease supplying the Wholesale International Private Leased Circuit Service as soon as practicable or at such time as specified by the Other Licensed Operator in accordance with terms and conditions specified in Clause 20 (Breach, Suspension and Termination) of the Primary Document.

5. **Charging**

5.1 For all Wholesale International Private Leased Circuit Services provided by STC, STC will collect the Wholesale International Private Leased Circuit Service charges from the Other Licensed Operator.

5.2 STC shall, for those Links for which it is providing a Wholesale International Private Leased Circuit Service, collate a record for each individual Link, which shall be used by STC to invoice for the Wholesale International Private Leased Circuit Service it provides under this RIO.

5.3 STC will charge the OLO on half Circuit basis for the International Private Leased Circuit Services that it provides to the OLO. The OLO will be responsible for all charges levied by the distant end operator for the other half circuit.

5.4 The calculation of Charges for the Wholesale International Private Leased Circuit Service will be based on the applicable rates set out in Annex F (*Price List*) of the RIO.

5.5 Charging commences upon the formal completion and handover of each circuit to the OLO by STC.

6. **Billing Information**

6.1 STC shall use its reasonable endeavours to provide appropriate Billing Information for the Wholesale International Private Leased Circuit Service in accordance with the format set out in Annex B (*Billing Processes and*

Procedures) within thirty (30) Business Days from the end of each Billing Period together with the invoice for the Wholesale International Private Leased Circuit Service as detailed in Annex B (*Billing Processes and Procedures*).

6.2 In addition to the obligation in Clause 6.1, when there is a dispute in relation to invoices issued for the Wholesale International Private Leased Circuit Service, the parties shall exchange the appropriate Billing Information.

6.3 In the event that STC cannot provide Billing Information for the Wholesale International Private Leased Circuit Service due to a system error or other faults, the Other Licensed Operator will be requested to provide appropriate Billing Information to STC in accordance with the procedure set out in Annex B (*Billing Processes and Procedures*).

6.4 Where the Billing Information collected by the Other Licensed Operator is not available under Clause 6.3, the Parties shall negotiate in good faith alternative Billing arrangements.

7. **Routing**

7.1 The provision of Wholesale International Private Leased Circuit shall be in accordance with the STC Transmission principles specified in Annex C (*Technical Information*).

SAUDI TELECOM COMPANY

Reference Interconnection Offer (RIO)

Annex G, Schedule 10

WHOLESALE

INTERNET CONNECTIVITY

Schedule (10) Wholesale Internet Connectivity

1. General

- 1.1 STC will supply the Wholesale Internet Connectivity Service to the Other Licensed Operator in accordance with Clause 3 of the Primary Document in respect of the Services for which the process in Clause 4 of this Schedule (10) has been followed.
- 1.2 For the avoidance of doubt, the process in Clause 4 of this Schedule (10) must be initiated by the Wholesale Internet Connectivity Service Other Licensed Operator if it wishes to acquire the Wholesale Internet Connectivity Service not previously covered by a request made under that Clause.
- 1.3 Notwithstanding the Interconnection of STC's Network and the Other Licensed Operator's network, STC shall have no obligation to provide services other than that specified for the provision of Wholesale Internet Connectivity Service within standard delivery lead-times where appropriate, (extended lead-times apply where plant is not available) and subject to engineering and commercial principles.
- 1.4 STC will only be required to provide the Wholesale Internet Connectivity Service to the Other Licensed Operator to the extent that the Other Licensed Operator has complied with Annex H (*Operations and Maintenance Manual*) and this Schedule (10).

2. Service Definition

<i>Interconnection Service</i>	<i>Definition</i>
Wholesale Internet Connectivity Service	A service whereby STC provides the Internet Connectivity to the OLO located in KSA by establishing the connectivity to the international internet hubs with which STC has operational/business agreements.

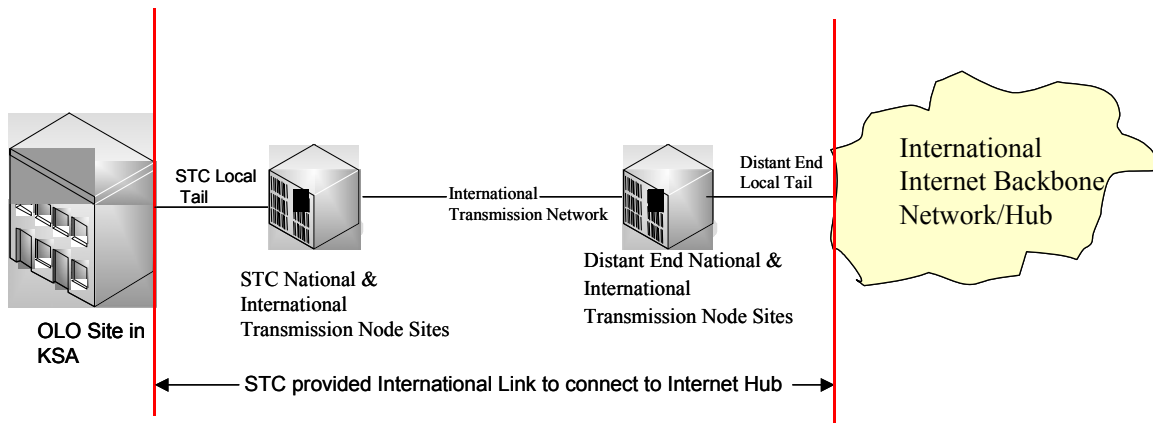

Figure 3: Wholesale Internet Connectivity Service in KSA

3. Description of Service

3.1 Subject to the provisions of this Schedule, STC shall provide the Wholesale Internet Connectivity Service by providing the (appropriate speed) transmission link from the site of the Other Licensed Operator in KSA to the distant country where the Internet Hub is located together with the necessary transmission links to the remote Internet hub. This service is based on STC's operational and business agreements with overseas operators and the International Internet Backbone Service Providers.

- 3.2 STC will provide the Wholesale Internet Connectivity connection to the Internet Backbone of one of its global Tier 1 partners in order to achieve optimum connectivity.
- 3.3 STC shall provide the Wholesale Internet Connectivity Service to the Other Licensed Operator for the contracted period and at the same standard and quality of service as it provides for similar links.
- 3.4 The Parties shall agree in advance all the necessary technical requirements, including physical circuit installation and operation for the provision of the Wholesale Internet Connectivity Service pursuant to this Schedule (10).
- 3.5 Each Party shall locate and correct faults that occur in its Network which affect the performance of the Wholesale Internet Connectivity Service in accordance with each Party's normal engineering practices. For the avoidance of doubt, neither Party warrants that its Network is, or will be, free from faults.
- 3.6 The provision of the Wholesale Internet Connectivity Service shall be in accordance with the STC Transmission routing principles specified in Annex C (*Technical Information*).
- 3.7 The Wholesale Internet Connectivity Service will be provided using agreed appropriate technology including both fixed and wireless systems.
- 3.8 For the provision of Wholesale Internet Connectivity Service, the Other Licensed Operator shall pay STC charges in accordance with the rates for such Links as specified from time to time in Annex F (*Price List*).

4. **Service Provisioning – Initial Procedure**

- 4.1 This Clause 4 applies where the Other Licensed Operator wishes to use the Wholesale Internet Connectivity Service provided by STC in respect of which the process in this Clause 4 has not already been undertaken.

- 4.2 The Other Licensed Operator shall notify STC by means of the request form set out in Annex H (*Operations and Maintenance Manual*) if it requests the use of the Wholesale Internet Connectivity Service.
- 4.3 STC shall acknowledge, in writing, receipt of the Other Licensed Operator's request under Clause 4.2 within five (5) Business Days of its receipt.
- 4.4 Following receipt of a request under Clause 4.2, STC shall assess that request and notify the Other Licensed Operator within ten (10) Business Days that either:
- a) The implementation of the request in respect of the requested Wholesale Internet Connectivity Service involves only network conditioning in STC's Network, in which case the negotiation period shall be thirty (30) Business Days; or
 - b) The implementation of the request in respect of the requested Wholesale Internet Connectivity Service involves work additional to or as an alternative to network conditioning in STC's Network, in which case the negotiation period shall be sixty (60) Business Days, or
 - c) Facilities are unavailable.
- 4.5 The Parties shall forthwith negotiate in good faith the requirements, implementation charges and timetable for the use of the Wholesale Internet Connectivity Service provided by STC in accordance with the Other Licensed Operator's request under Clause 4.2 for the negotiation period specified in Clause 4.4 (a) and (b) failing which either Party may commence the Dispute Resolution Procedure as defined in Clause 19 of the Primary Document.
- 4.6 Where the Parties have reached an agreement, in accordance with 4.4 (a) and (b) above, STC will commence implementation in accordance with the agreed timetable and in line with the delivery schedules contained in Annex I (*Quality of Service Measure*).

- 4.7 Nothing in this Clause 4 requires STC to perform any changes in its Network or to commence the supply of the Wholesale Internet Connectivity Service until the Parties have completed the preparation for that Wholesale Internet Connectivity Service and all network conditioning Charges have been agreed to by the Other Licensed Operator.
- 4.8 The Other Licensed Operator may, at any time, request STC to cease supplying the Wholesale Internet Connectivity Service and STC shall cease supplying the Wholesale Internet Connectivity Service as soon as practicable or at such time as specified by the Other Licensed Operator in accordance with terms and conditions specified in Clause 20 (Breach, Suspension and Termination) of the Primary Document.
5. **Charging**
- 5.1 For all Wholesale Internet Connectivity Services provided by STC, STC will collect the Wholesale Internet Connectivity Service charges from the Other Licensed Operator.
- 5.2 STC shall, for those Links for which it is providing a Wholesale Internet Connectivity Service, collate a record for each individual Link, which shall be used by STC to invoice for the Wholesale Internet Connectivity Service it provides under this RIO.
- 5.3 STC will charge the Other Licensed Operator on a full circuit basis for the Wholesale Internet Connectivity that it provides to the Other Licensed Operator.
- 5.4 The calculation of Charges for the Wholesale Internet Connectivity Service will be based on the applicable rates set out in Annex F (*Price List*).
- 5.5 The STC charges for Wholesale Internet Connectivity reflects a single price if solution is delivered in Jeddah, Riyadh, or Dammam.

- 5.6 Content filtering may be provided at an additional cost, on the basis of requirements and mutual agreement.
- 5.7 Charging commences upon the formal completion of the handover of each circuit.

6. **Billing Information**

- 6.1 STC shall use its reasonable endeavours to provide Billing Information for the Wholesale Internet Connectivity Service in accordance with the format set out in Annex B (*Billing Processes and Procedures*) within thirty (30) Business Days from the end of each Billing Period together with the invoice for the Wholesale Internet Connectivity Service in accordance with Annex B (*Billing Processes and Procedures*).
- 6.2 In addition to the obligation in Clause 6.1, when there is a dispute in relation to invoices issued for the Wholesale Internet Connectivity Service, the parties shall exchange the appropriate Billing Information.
- 6.3 In the event that STC cannot provide the appropriate Billing Information for the Wholesale Internet Connectivity Service due to a system error or other faults, the Other Licensed Operator will be requested to provide appropriate Billing Information to STC in accordance with the procedure set out in Annex B (*Billing Processes and Procedures*).
- 6.4 Where the Billing Information collected by the Other Licensed Operator is not available under Clause 6.3, the Parties shall negotiate in good faith alternative Billing arrangements.

7. **Routing**

- 7.1 The provision of the Wholesale Internet Connectivity Service shall be in accordance with the STC Transmission principles specified in Annex C (*Technical Information*).